

Vickers®

## Vane Pumps

---



### VMQ Series Vane Pumps

For Industrial and Mobile Applications  
Displacements to 215 cm<sup>3</sup>/r (13.12 in<sup>3</sup>/r)  
Pressures to 260 bar (3800 psi)



5008.00/EN/0596/A

# Introduction

From the very beginning, Vickers has been at the forefront of fluid power technology. Our vane pumps have always been the standard against which all others are measured.

Now we proudly announce our newest state-of-the-art fixed displacement vane pumps – the VMQ Series for industrial and mobile applications. Compared to less advanced designs, they provide higher performance, higher pressure capability, and expanded displacements – all with comparable low noise characteristics. With a wide variety of single and double pump configurations, there's sure to be a model ready to satisfy your most demanding requirements.

## Performance

VMQ pumps meet SAE and ISO standards. Two single-pump frame sizes – 25 and 35 – are available in 16 flows ranging from 4.8 to 64.2 USgpm (@1800 rpm). Two double-pump configurations offer combined flows ranging from 9.7 to 102.2 USgpm. Continuous outlet pressures rated up to 260 bar (3800 psi) are standard. Intermittent pressures up to 290 bar (4200 psi) are allowed.

## Features and Benefits

- Shafts easily handle maximum pressures for exceptional shaft life.
  - Design allows for configurations with different directions of rotation, inlet/outlet orientations, drives and mounting flanges.
  - Performs under harshest speed, temperature, and cyclical loading conditions.
  - Removeable cartridge makes it easy to modify flow size, or repair pump. Usually, cartridge can be replaced without removing pump from its mounting.
  - Cartridges are interchangeable between single and double pumps, simplifying cartridge selection and inventory.
  - Sixteen displacements allow selection of right pump to maximize use of energy.
  - Four-bolt leak-free flange connections on all ports. Meets all current SAE and ISO standards
  - Choice of SAE or ISO two-bolt mounting means compatibility with all popular mobile or industrial mounting arrangements.
- Changing direction of rotation is quick and easy due to pumps' symmetrical cartridge design.
  - Extremely quiet for enhanced operator comfort.
  - High volumetric efficiencies.
  - Compatible with various fluids.
  - Hydraulically-balanced design means there are no internal radial forces to load the shaft or bearings. In absence of external radial and axial shaft loading, this assures virtually limitless shaft and bearing life.
  - Positive shaft seal available as single seal for "dry mount" applications, or as double seal design for fluid separation on "wet mount" applications. Wet mounts (gear-box or other lubricant always present) extend shaft-spline life.

Model Series	Maximum Geometric Displacement cm <sup>3</sup> /r (in <sup>3</sup> /r)	Maximum Operating Pressure bar (psi)	Maximum Operating Speed r/min	
			Industrial Rating	Mobile Rating
25VMQ single pump	80 (4.88)	260 (3800)	1800	3000
35VMQ single pump	135 (8.24)	230 (3300)	1800	2400
2525VMQ double pump	80 (4.88) shaft end 80 (4.88) cover end	260 (3800) 260 (3800)	1800	3000
3525VMQ double pump	135 (8.24) shaft end 80 (4.88) cover end	230 (3300) 260 (3800)	1800	2400

VMQ Single

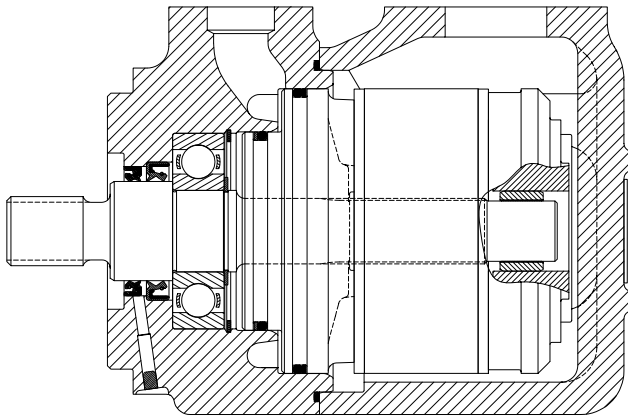



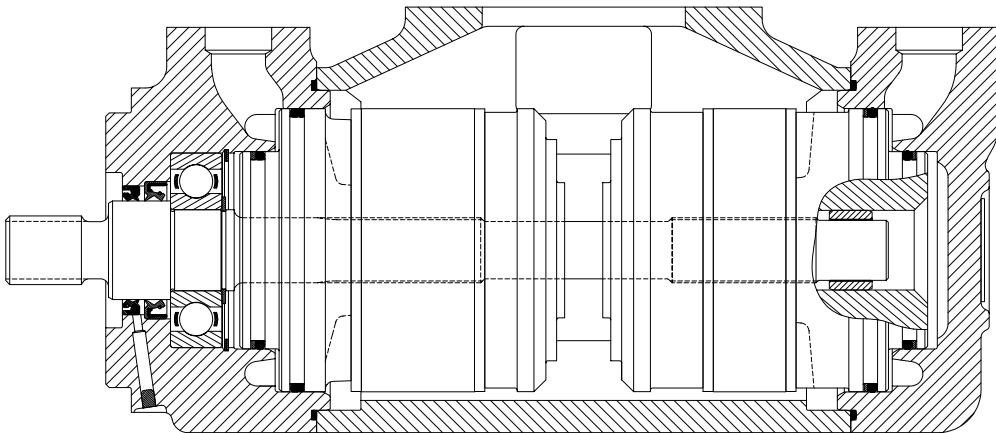























VMQ Double



# Contents

---

Operational Recommendations .....	A.29	
<b>25VMQ Single Pumps</b>		
Performance Data .....	A.30	
Sound Data .....	A.31	
Model Code .....	A.32	
Industrial Delivery and Input Power Curves .....	A.33	
Mobile Delivery and Input Power Curves .....	A.43	
Installation Dimensions .....	A.53	
<b>35VMQ Single Pumps</b>		
Performance Data .....	A.54	
Sound Data .....	A.54	
Model Code .....	A.55	
Industrial Delivery and Input Power Curves .....	A.56	
Mobile Delivery and Input Power Curves .....	A.62	
Installation Dimensions .....	A.68	
<b>2525VMQ Double Pumps</b>		
Performance Data .....	A.69	
Sound Data .....	A.70	
Model Code .....	A.71	
Installation Dimensions .....	A.72	
<b>3525VMQ Double Pumps</b>		
Performance Data .....	A.73	
Sound Data .....	A.75	
Model Codes .....	A.76	
Installation Dimensions .....	A.77	
<b>Single and Double Pumps</b>		
Shaft Dimensions .....	A.78	
Torque Loading for Direct Drives .....	A.80	
Fluid Cleanliness .....	A.81	
Additional Data		
Fluid Selection .....	A.82	
Moments of Inertia .....	A.82	
Weights .....	A.82	

# Operational Recommendations

## Cold starts

When operating with SAE 10W oil in the 860 to 54 cSt (4000 to 251 SUS) range, the pressure should be limited to 50% or less of its rated value until the system has warmed up; for mobile applications, the speed should also be limited to 50% or less. Extreme caution must be used when starting pumps when fluid viscosities are greater than 860 cSt (4000 SUS). Care should be exercised to warm up the entire system, including remote cylinders and motors.

## High temperatures

Viscosities must not be less than the minimum values shown in the table below. Temperatures should not exceed 99°C (210°F) because the life expectancy of cartridge kits and elastomers will decrease.

## Drive data

Pumps are assembled for right hand (clockwise) rotation or left hand (counterclockwise) rotation. Rotation is viewed from the shaft end. Inlet and outlet ports remain the same regardless of the direction of shaft rotation.

## Pump drive

Direct coaxial drive is recommended. If drives imposing radial shaft loads are considered, please consult your Vickers representative.

## Start-up procedure

Make sure the reservoir and circuit are clean and free of dirt/debris prior to filling with hydraulic fluid.

Fill the reservoir with filtered oil and fill to a level sufficient enough to prevent vortexing at suction connection to pump inlet. It is good practice to clean up the system by flushing and filtering using an external slave pump.

Before starting the pump, fill with fluid through one of the ports. This is particularly important if the pump is above the fluid level of the reservoir.

When initially starting the pump, remove all trapped air from the system. This can be accomplished by loosening the pump outlet fittings or connections before starting the pump or by using an air bleed valve. All inlet connections must be tight to prevent air leaks. An air bleed valve is available for this purpose. (Refer to catalog 690).

CAUTION: – No Case Drain.

These pumps are drained internally into their inlet. System pressure at the pump inlet connection may not exceed 1,4 bar (20 psi).

CAUTION: – Low Outlet Pressure.

Do not run a pump with the outlet pressure lower than the inlet pressure. This causes operating noise and vane instability.

Once the pump is started, it should prime within a few seconds. If the pump does not prime, check to make sure that there are no restrictions between the reservoir and the inlet to the pump, and that there are no air leaks in the inlet line and connections. Also check to make sure that trapped air can escape at the pump outlet.

After the pump is primed, tighten the loose outlet connections, then operate for five to ten minutes unloaded to remove all trapped air from the circuit.

If the reservoir has a sight gage, make sure the fluid is clear – not milky.

## Inlet Pressure and Operating Temperature Requirements

Application	Recommended Operating Inlet Pressure – gauge bar (psi)	Maximum Positive Inlet Pressure – gauge bar (psi)	Minimum Inlet Pressure – absolute bar (psia)	Maximum Operating Temperature °C (°F)	Maximum Transient Operating Temperature °C (°F)
Industrial	0 to 0,35 (0 to 5.0)	1,4 (20)	0,83 (12.0)	66 (150)	74 (165)
Mobile			1,0 (14.5)	93 (200)	99 (210)

## Viscosity Requirements

Application	Recommended Operating Viscosity Range cSt	Maximum Viscosity at Startup cSt	Minimum Viscosity cSt	
			Continuous	Intermittent
Industrial	13 to 54	865	13	10
Mobile			10	6.5

# 25VMQ Typical Performance Data

## Maximum Operating Pressure

260 bar (3800 psi)

## Maximum Transient Pressure (peak < 0.5 sec)

290 bar (4200 psi)

## Industrial Displacement, Speed, Flow, & Power Ratings 120° F, SAE 10W oil, 0 psig inlet

Ring Size Code	Maximum Geometric Displacement cm <sup>3</sup> /r (in <sup>3</sup> /r)	Maximum Operating Speed rpm	Output Flow at 1500 rpm, 210 bar (3000 psi) l/min (USgpm)	Input Power at 1500 rpm, 210 bar (3000 psi) kw (hp)	Output Flow at 1800 rpm, 210 bar (3000 psi) l/min (USgpm)	Input Power at 1800 rpm, 210 bar (3000 psi) kw (hp)
010	10 (0.62)	1800	11,39 (3.01)	6,24 (8.37)	14,7 (3.88)	7,55 (10.12)
016	16 (0.98)	1800	20,24 (5.35)	9,29 (12.46)	25,32 (6.69)	11,21 (15.03)
020	20 (1.23)	1800	26,38 (6.97)	11,41 (15.30)	32,70 (8.64)	13,75 (18.44)
025	25 (1.58)	1800	34,98 (9.24)	14,37 (19.28)	43,02 (11.37)	17,31 (23.21)
032	32 (1.96)	1800	44,32 (11.71)	17,59 (23.59)	54,23 (14.33)	21,17 (28.39)
040	40 (2.44)	1800	50,14 (13.25)	22,88 (30.68)	61,74 (16.31)	27,46 (36.82)
045	45 (2.75)	1800	57,63 (15.23)	25,46 (34.14)	70,74 (18.69)	30,56 (40.98)
050	50 (3.05)	1800	65,13 (17.21)	28,04 (37.61)	79,73 (21.07)	33,66 (45.14)
063	63 (3.84)	1800	84,55 (22.34)	34,74 (46.58)	103,03 (27.22)	41,69 (55.91)
071	71 (4.33)	1800	96,59 (25.52)	38,89 (52.15)	117,48 (31.04)	46,67 (62.59)
080	80 (4.88)	1800	110,11 (29.09)	43,55 (58.40)	133,71 (35.33)	52,26 (70.09)

Note: Do not operate at speeds, pressures, and/or viscosities where internal leakage exceeds 50% of theoretical value.; i.e., actual flow must exceed 50% of theoretical flow.

## Mobile Displacement, Speed, Flow, & Power Ratings 180° F, SAE 10W oil, 0 psig inlet

Ring Size Code	Maximum Geometric Displacement cm <sup>3</sup> /r (in <sup>3</sup> /r)	Maximum Operating Speed rpm	Output Flow at Maximum rpm, 210 bar (3000 psi) l/min (USgpm)	Input Power at Maximum rpm, 210 bar (3000 psi) kw (hp)
010	10 (0.62)	3000	22,38 (5.91)	12,92 (17.33)
016	16 (0.98)	3000	40,07 (10.59)	19,03 (25.51)
020	20 (1.23)	3000	52,36 (13.83)	23,26 (31.19)
025	25 (1.58)	3000	69,57 (18.38)	29,19 (39.15)
032	32 (1.96)	3000	88,25 (23.32)	35,63 (47.78)
040	40 (2.44)	2600	81,19 (21.45)	39,96 (53.59)
045	45 (2.75)	2600	94,18 (24.88)	44,44 (59.59)
050	50 (3.05)	2600	107,17 (28.32)	48,92 (65.60)
063	63 (3.84)	2600	140,83 (37.21)	60,52 (81.16)
071	71 (4.33)	2600	161,70 (42.72)	67,72 (90.81)
080	80 (4.88)	2400	169,43 (44.76)	69,80 (93.60)

Note: Do not operate at speeds, pressures, and/or viscosities where internal leakage exceeds 50% of theoretical value.; i.e., actual flow must exceed 50% of theoretical flow.

# 25VMQ Typical Sound Data

120° F, SAE 10W oil, 0 psig inlet

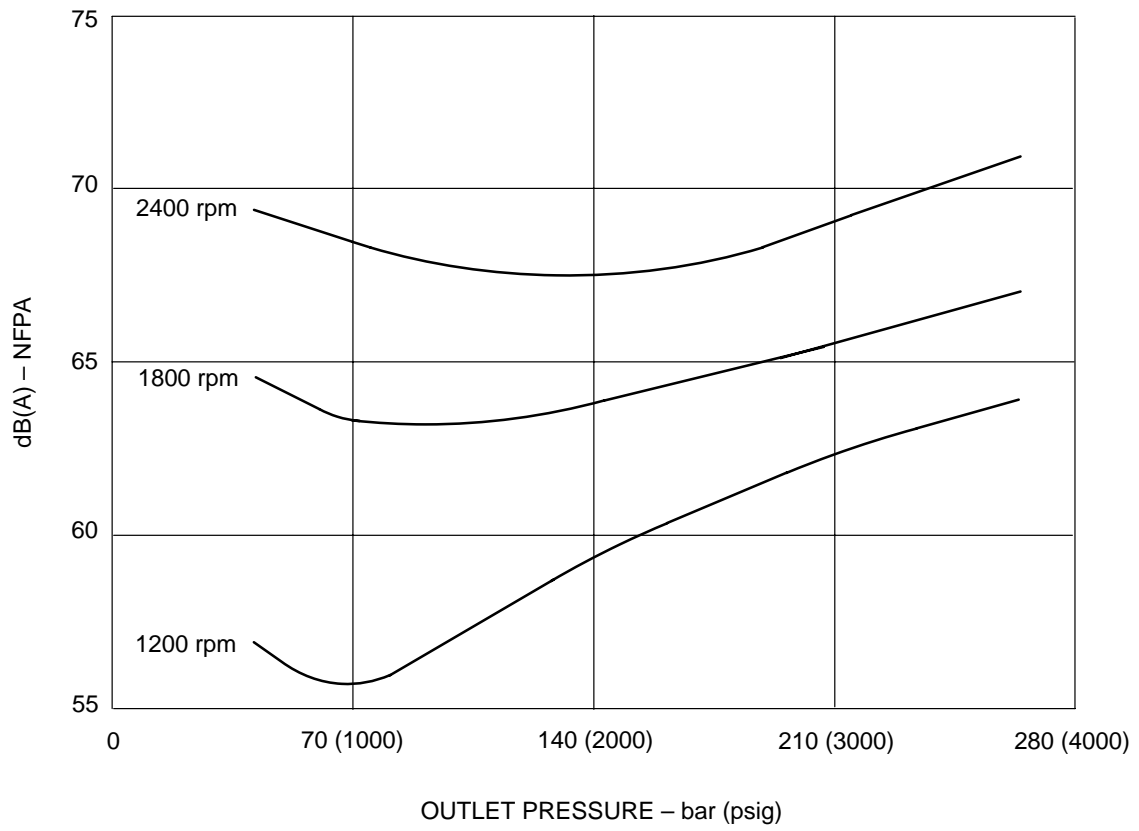

# 25VMQ Model Code

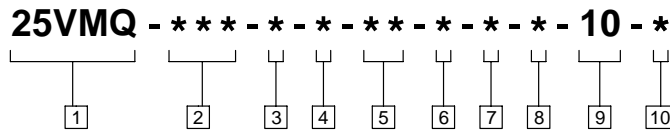

**1 Series designation (frame size)**

25VMQ – 10 to 80 cm<sup>3</sup>/r  
(0.62 to 4.88 in<sup>3</sup>/r)

**2 Displacement**

- 010 – 10 cm<sup>3</sup>/r (0.62 in<sup>3</sup>/r)
- 016 – 16 cm<sup>3</sup>/r (0.98 in<sup>3</sup>/r)
- 020 – 20 cm<sup>3</sup>/r (1.23 in<sup>3</sup>/r)
- 025 – 25 cm<sup>3</sup>/r (1.58 in<sup>3</sup>/r)
- 032 – 32 cm<sup>3</sup>/r (1.96 in<sup>3</sup>/r)
- 040 – 40 cm<sup>3</sup>/r (2.44 in<sup>3</sup>/r)
- 045 – 45 cm<sup>3</sup>/r (2.75 in<sup>3</sup>/r)
- 050 – 50 cm<sup>3</sup>/r (3.05 in<sup>3</sup>/r)
- 063 – 63 cm<sup>3</sup>/r (3.84 in<sup>3</sup>/r)
- 071 – 71 cm<sup>3</sup>/r (4.33 in<sup>3</sup>/r)
- 080 – 80 cm<sup>3</sup>/r (4.88 in<sup>3</sup>/r)

**3 Port connection**

- A – SAE 4-bolt flange (SAE J518)
- B – Metric 4-bolt flange (ISO 6162)

**4 Flange mounting style**

- A – SAE J744 101–2 (SAE B)
- B – ISO 3019/2 100A2HW

**5 Shaft end**

- 01 – SAE J744 25–1  
(1.00 inch, keyed)
- 02 – SAE J744 25–4  
(B–B splined )
- 03 – ISO 3019/2 E25N  
(25mm, keyed)
- 05 – SAE J744 32–1  
(1.25 inch, keyed)
- 06 – SAE J744 32–4  
(C splined)
- 07 – ISO 3019/2 E32N  
(32mm, keyed)
- 09 – SAE J744 22–4  
(B splined)

**6 Shaft seal**

- A – Single, primary
- B – Double, secondary (spring side out)
- C – Double, secondary (spring side in)

**7 Seal type**

- N – Standard, buna N
- V – Viton
- W – Buna N with Viton shaft seal(s)

**8 Outlet port position  
(viewed from cover end)**

- A – Outlet port opposite inlet port
- B – Outlet port 90° counterclockwise from inlet port
- C – Outlet port inline with inlet port
- D – Outlet port 90° clockwise from inlet port

**9 Design level**

Subject to change. Dimensions remain the same for designs 10 through 19.

**10 Rotation  
(viewed from shaft end)**

- R – Right hand (clockwise)
- L – Left hand (counterclockwise)

# 25VMQ (Industrial) Typical Delivery

Delivery of Code 032, 020, and 010 Displacement Cartridges  
 at 120° F, SAE 10W Oil, 0 psig Inlet

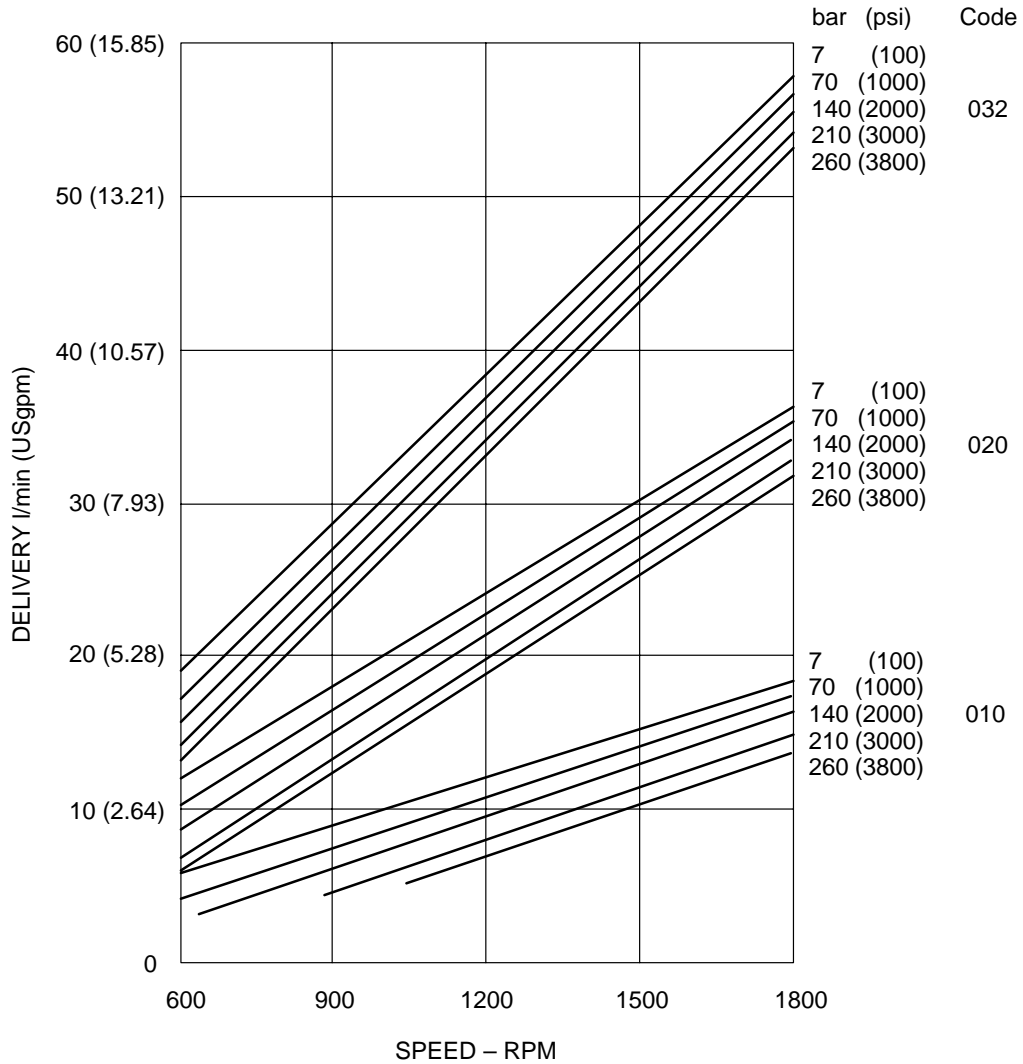

# 25VMQ (Industrial) Typical Delivery

Delivery of Code 025 and 016 Displacement Cartridges  
at 120° F, SAE 10W Oil, 0 psig Inlet

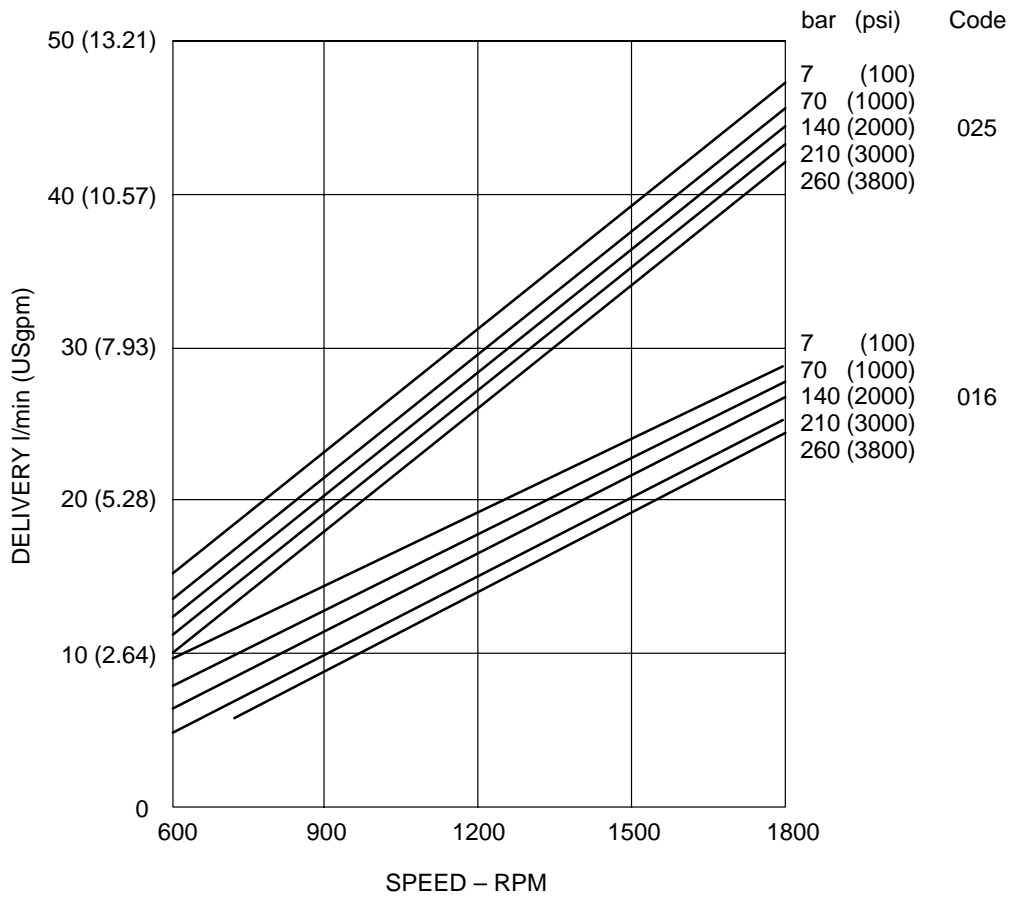

# 25VMQ (Industrial) Typical Delivery

Delivery of Code 080 and 050 Displacement Cartridges  
at 120° F, SAE 10W Oil, 0 psig Inlet

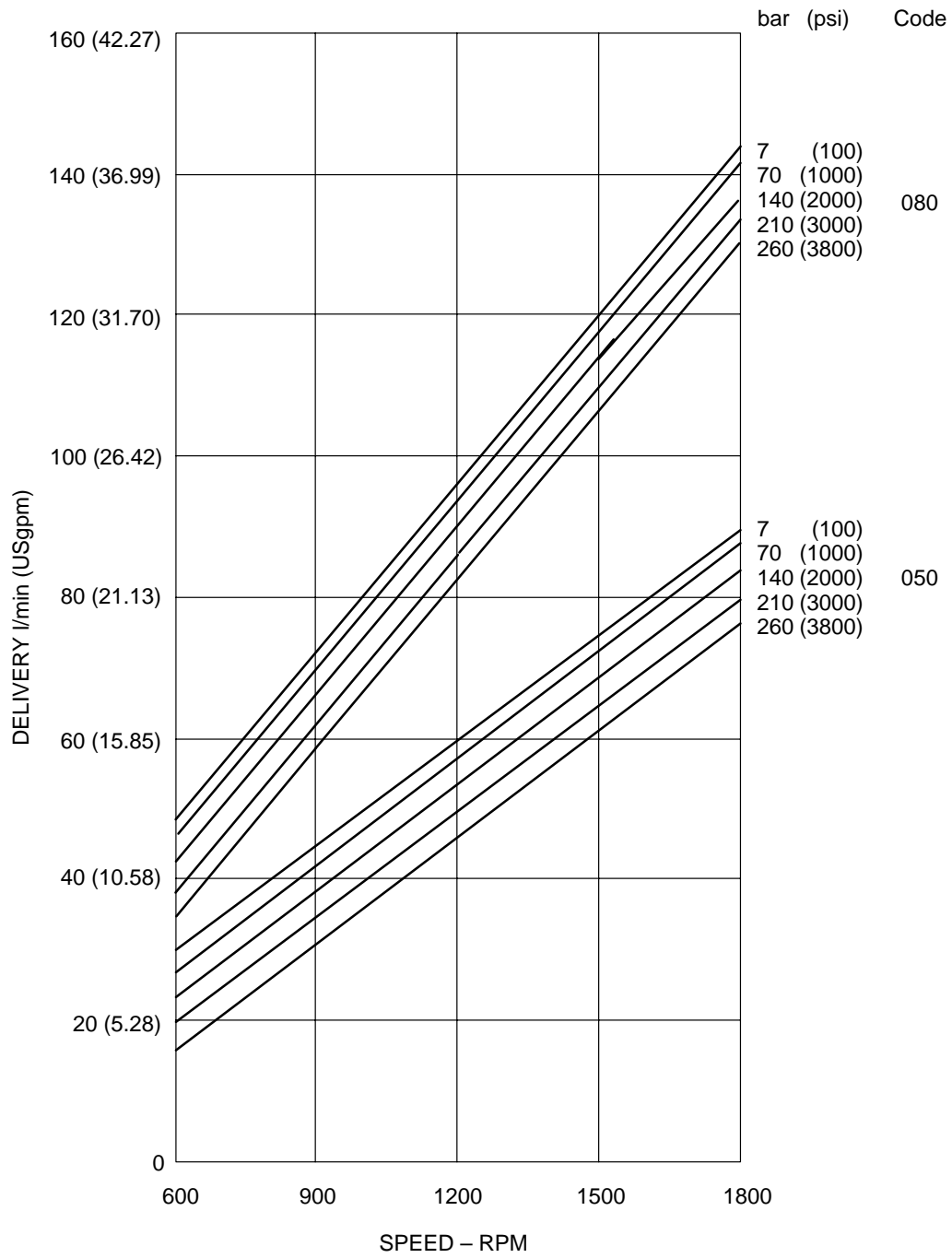

# 25VMQ (Industrial) Typical Delivery

Delivery of Code 071 and 045 Displacement Cartridges  
at 120° F, SAE 10W Oil, 0 psig Inlet

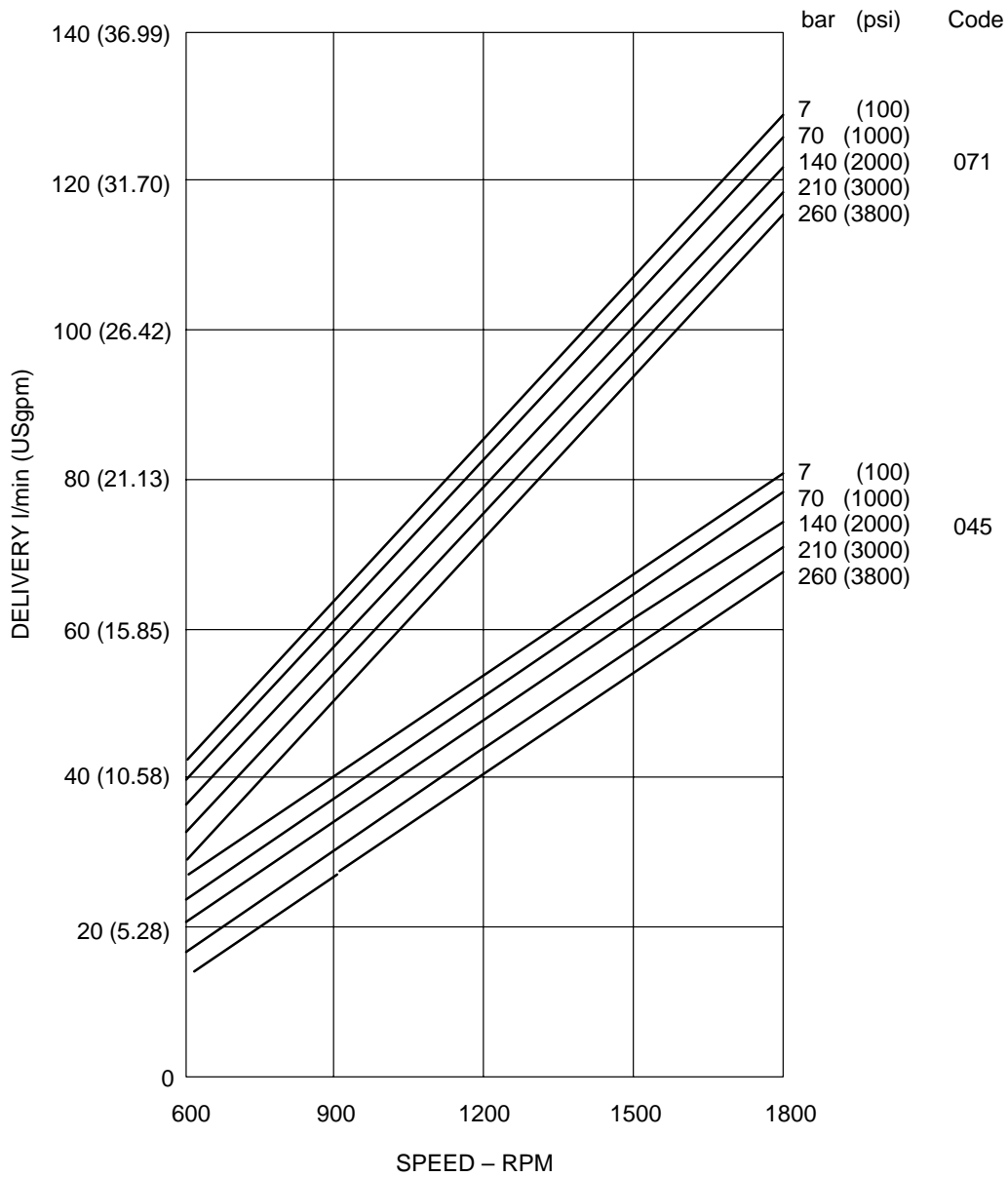

# 25VMQ (Industrial) Typical Delivery

Delivery of Code 063 and 040 Displacement Cartridges  
at 120° F, SAE 10W Oil, 0 psig Inlet

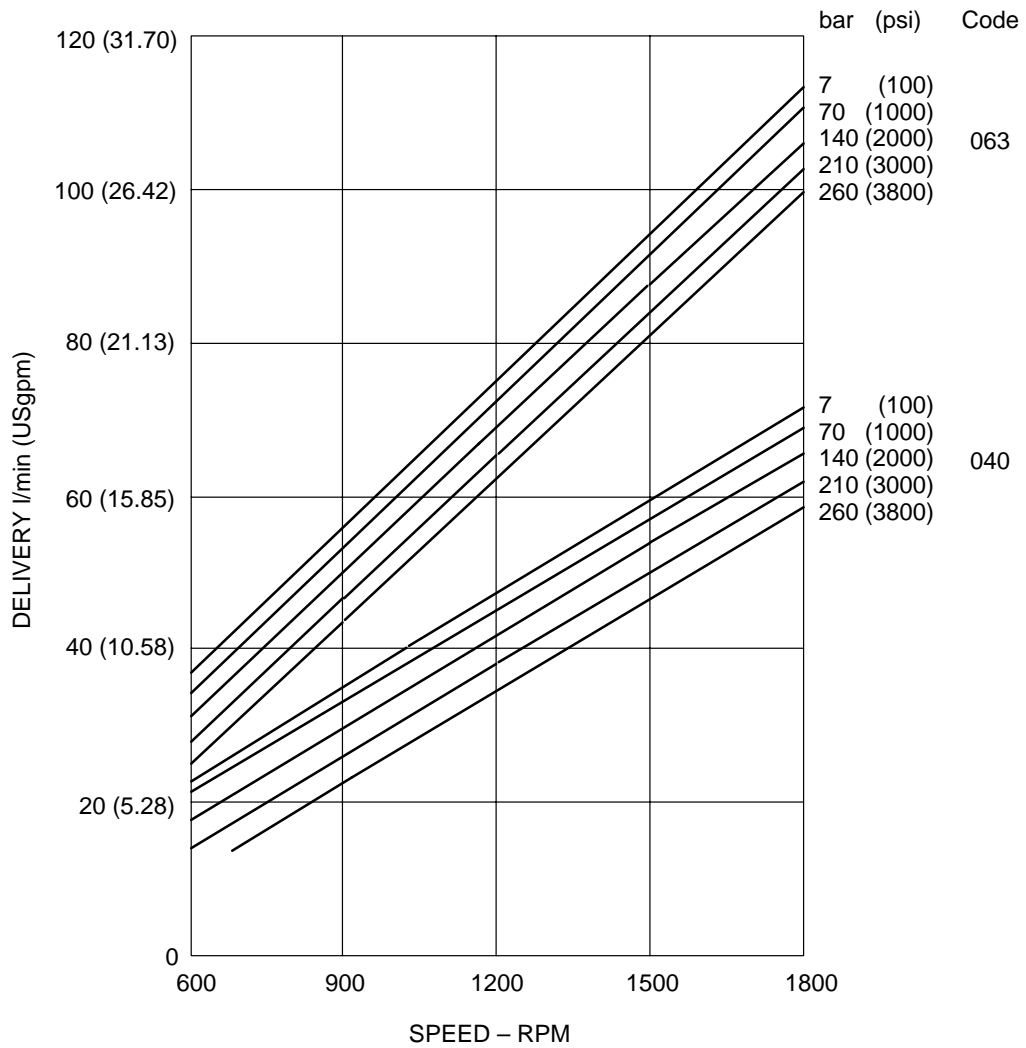

# 25VMQ (Industrial) Typical Input Power

Input Power of Code 032 and 020 Displacement Cartridges  
at 120° F, SAE 10W Oil, 0 psig Inlet

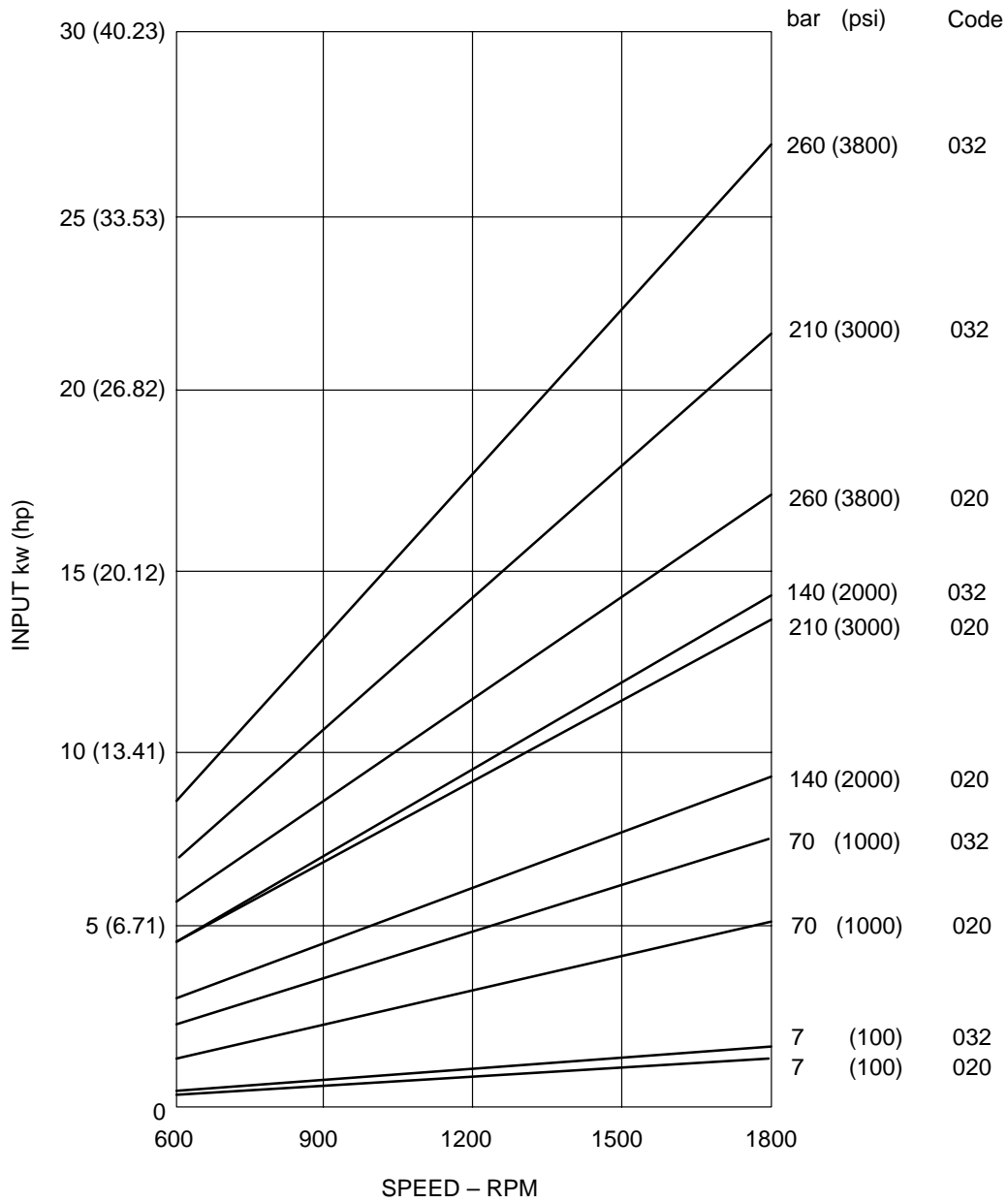

# 25VMQ (Industrial) Typical Input Power

Input Power of Code 025, 016, and 010 Displacement Cartridges  
at 120° F, SAE 10W Oil, 0 psig Inlet

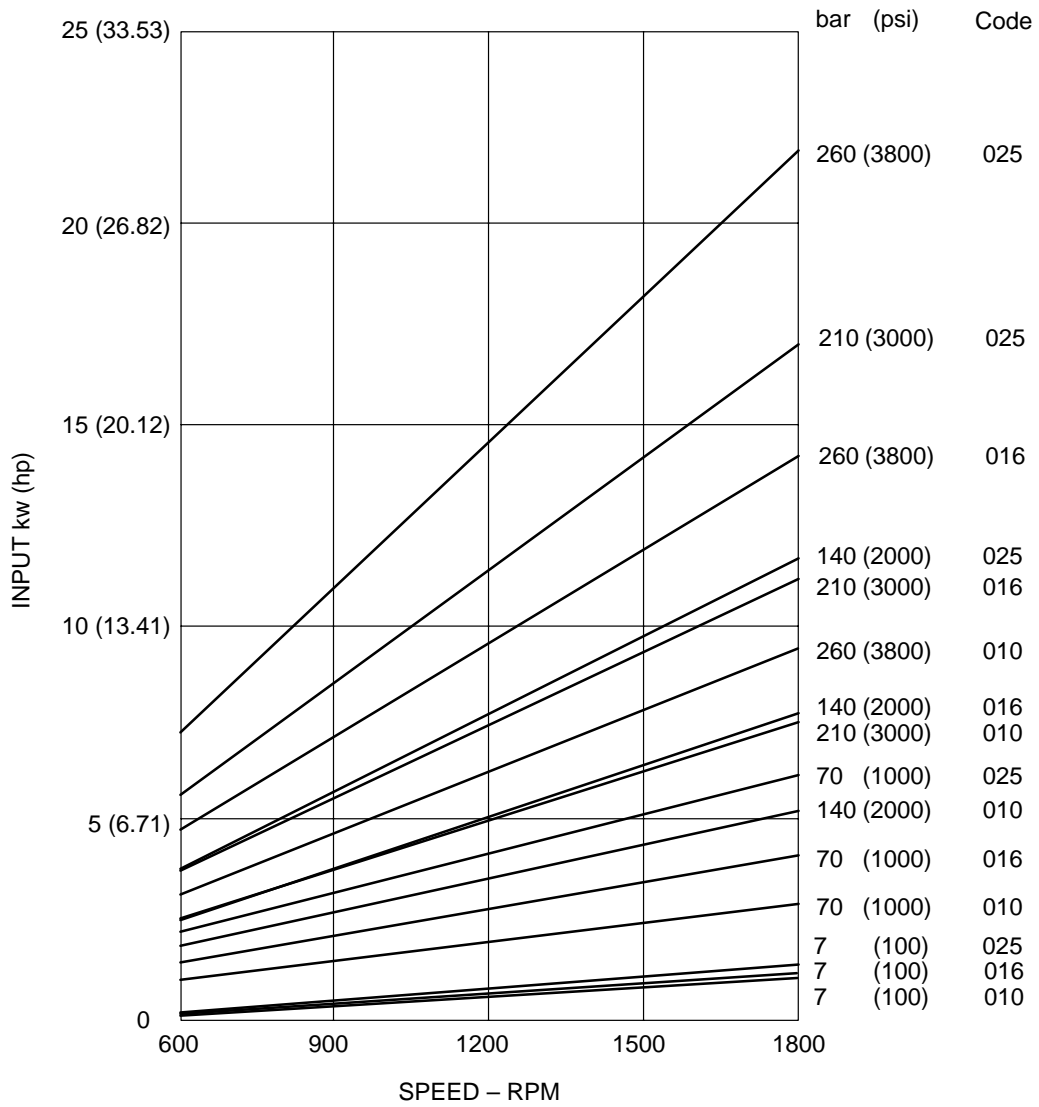

# 25VMQ (Industrial) Typical Input Power

Input Power of Code 080 and 050 Displacement Cartridges  
at 120° F, SAE Oil, 0 psig Inlet

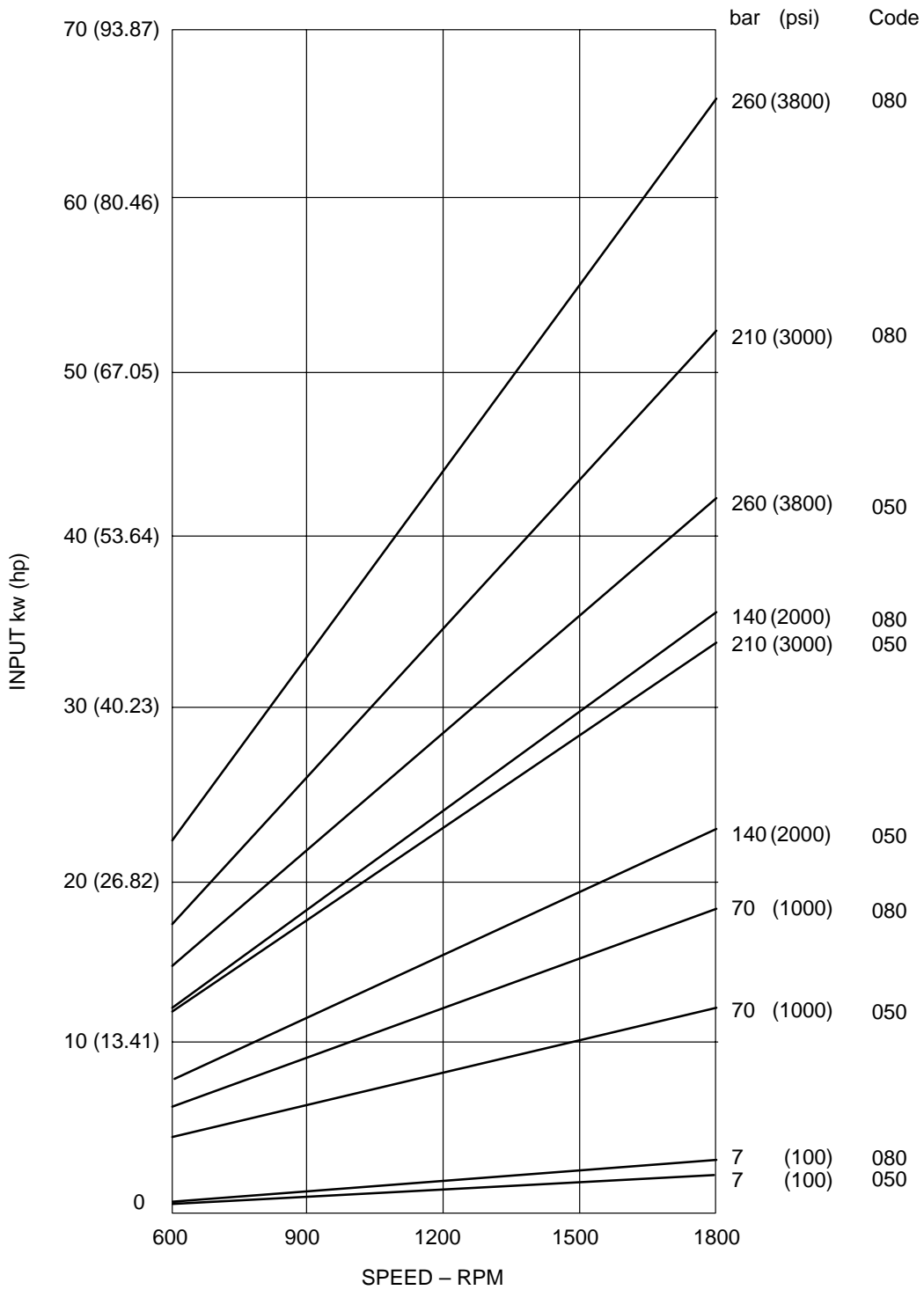

# 25VMQ (Industrial) Typical Input Power

Input Power of Code 071 and 045 Displacement Cartridges  
at 120° F, SAE 10W Oil, 0 psig Inlet

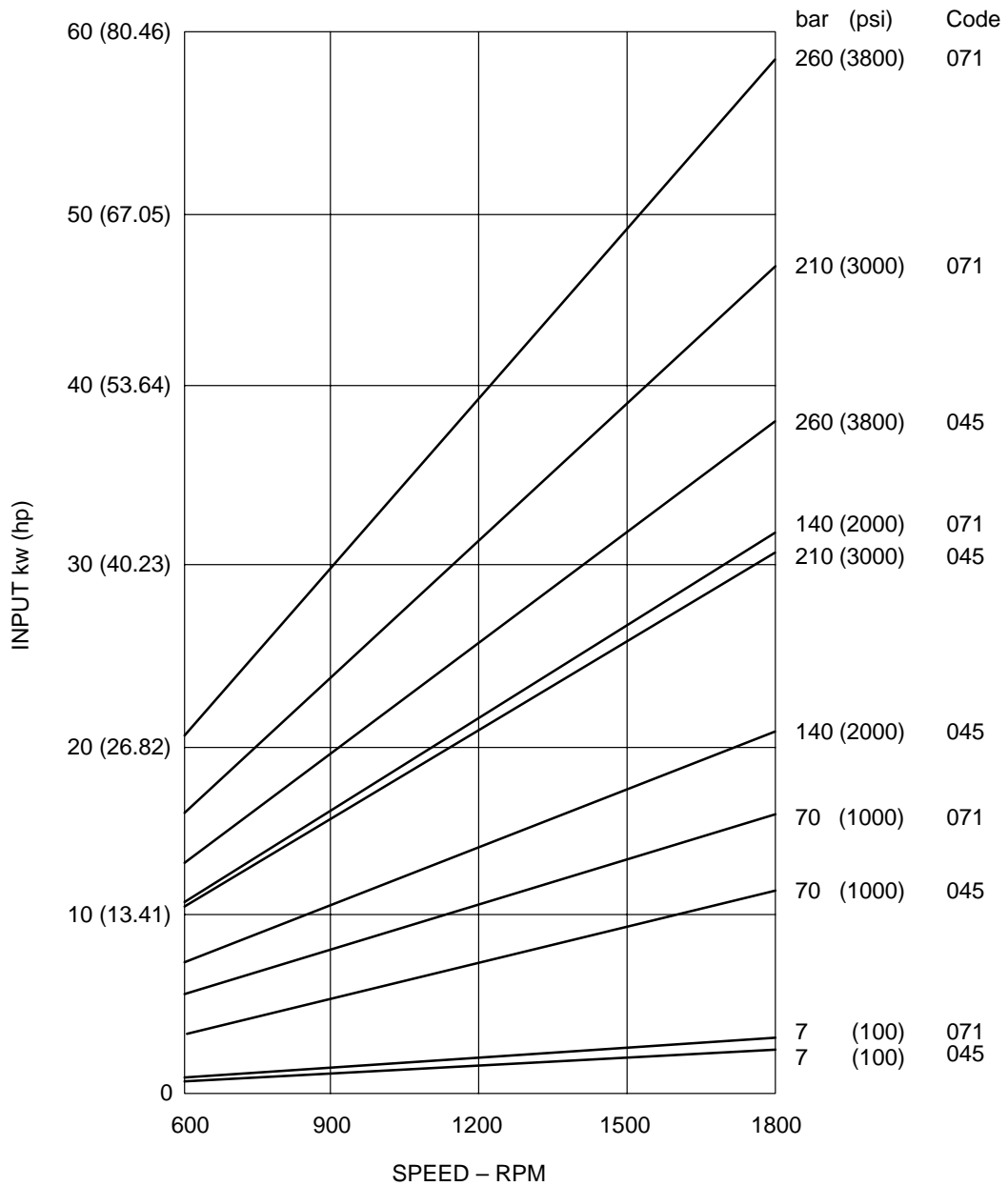

# 25VMQ (Industrial) Typical Input Power

Input Power of Code 063 and 040 Displacement Cartridges  
at 120° F, SAE 10W Oil, 0 psig Inlet

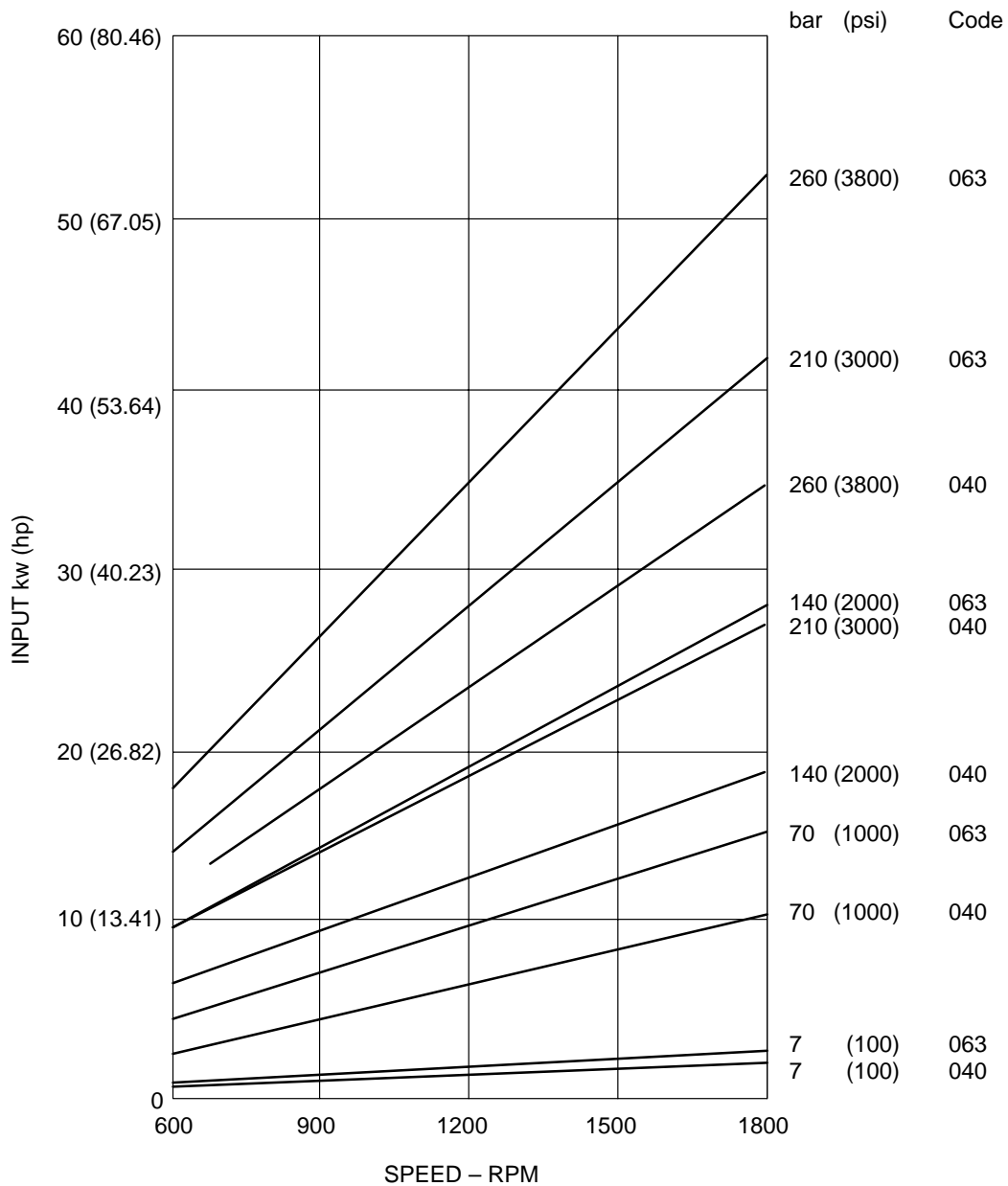

# 25VMQ (Mobile) Typical Delivery

Delivery of Code 032, 020, and 010 Displacement Cartridges  
at 180° F, SAE 10W Oil, 0 psig Inlet

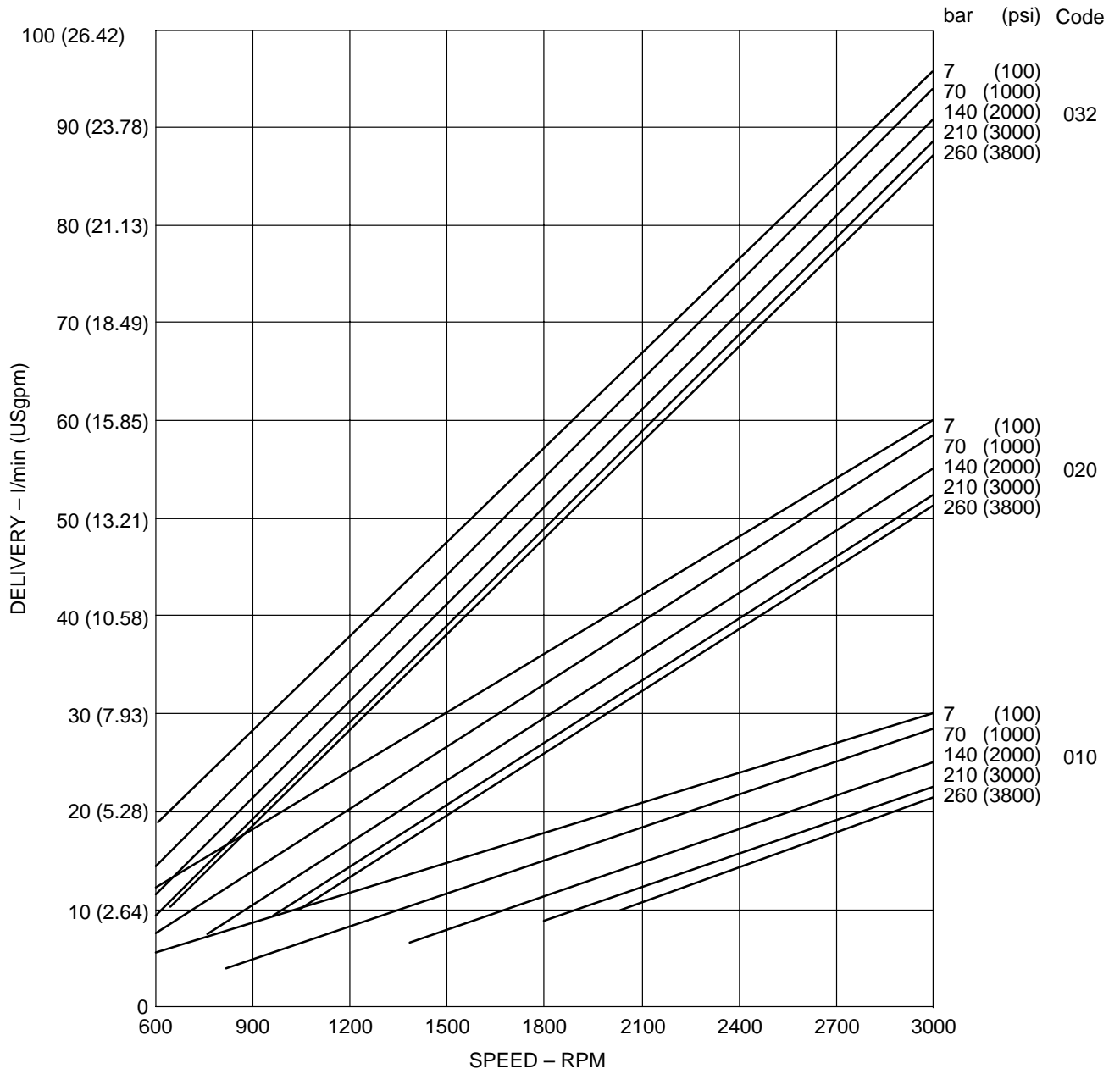

# 25VMQ (Mobile) Typical Delivery

Delivery of Code 025 and 016 Displacement Cartridges  
at 180° F, SAE 10W Oil, 0 psig Inlet

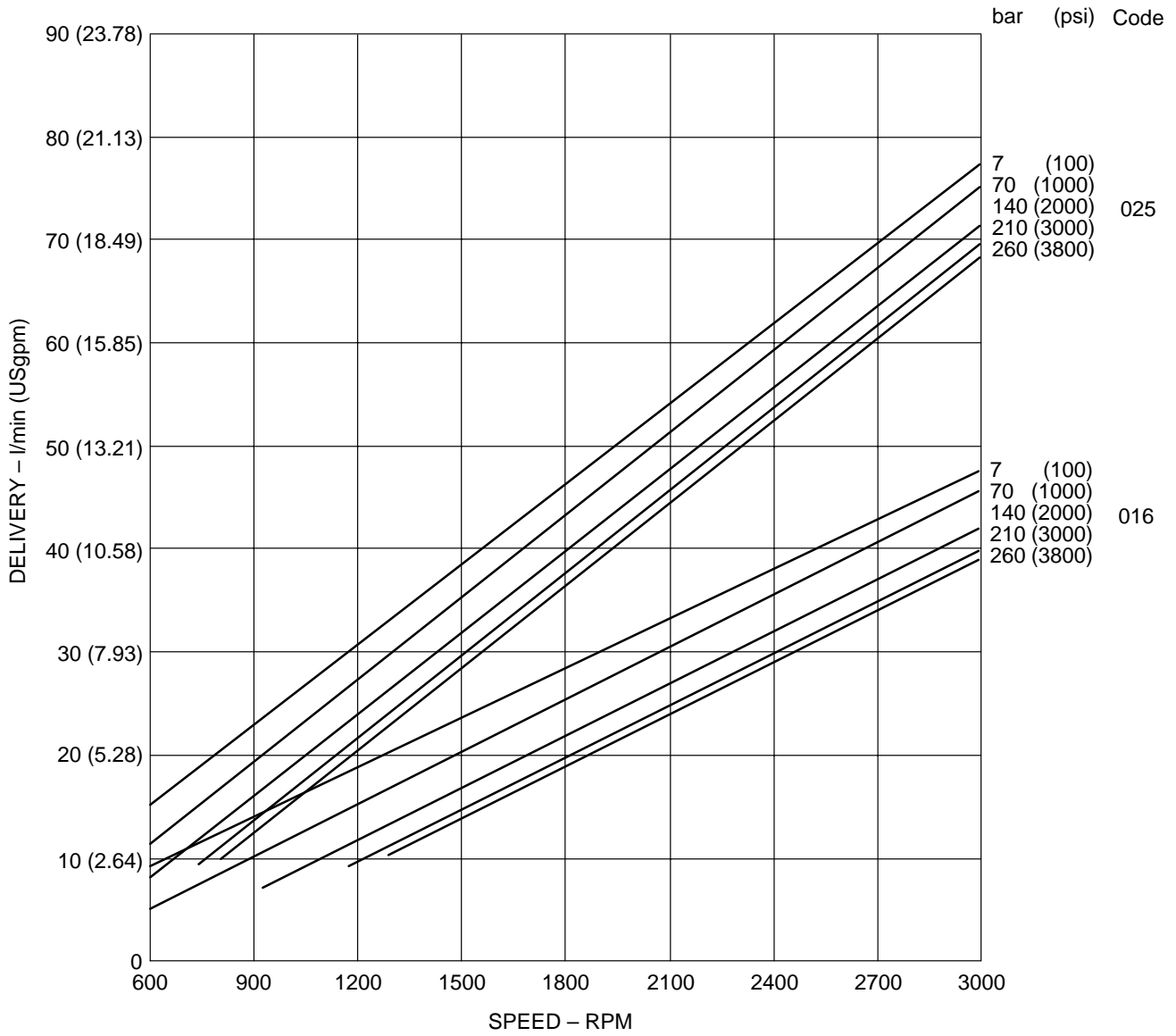

# 25VMQ (Mobile) Typical Delivery

Delivery of Code 080 and 050 Displacement Cartridges  
 at 180° F, SAE 10W Oil, 0 psig Inlet

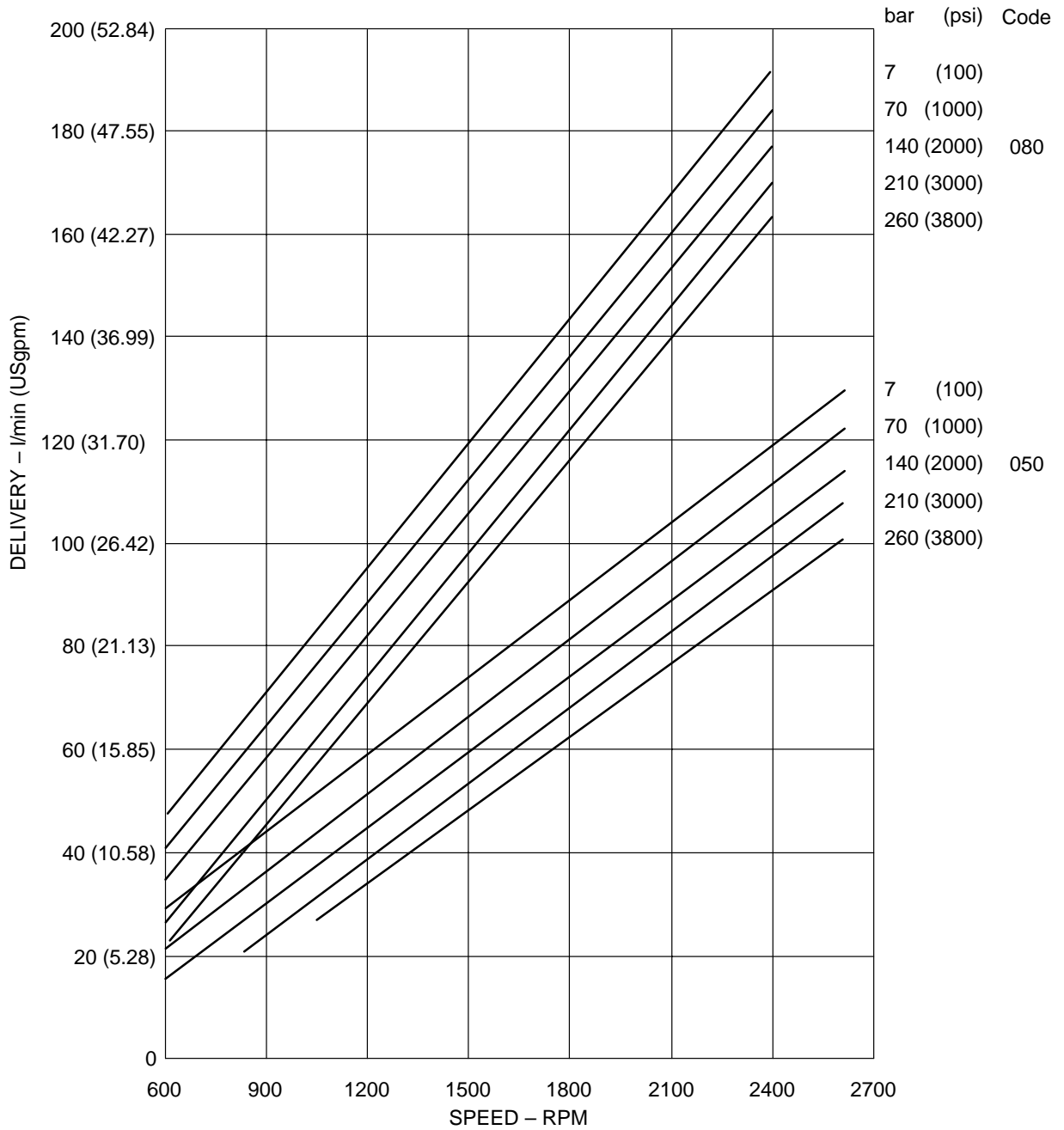

# 25VMQ (Mobile) Typical Delivery

Delivery of Code 071 and 045 Displacement Cartridges  
at 180°F, SAE 10W Oil, 0 psig Inlet

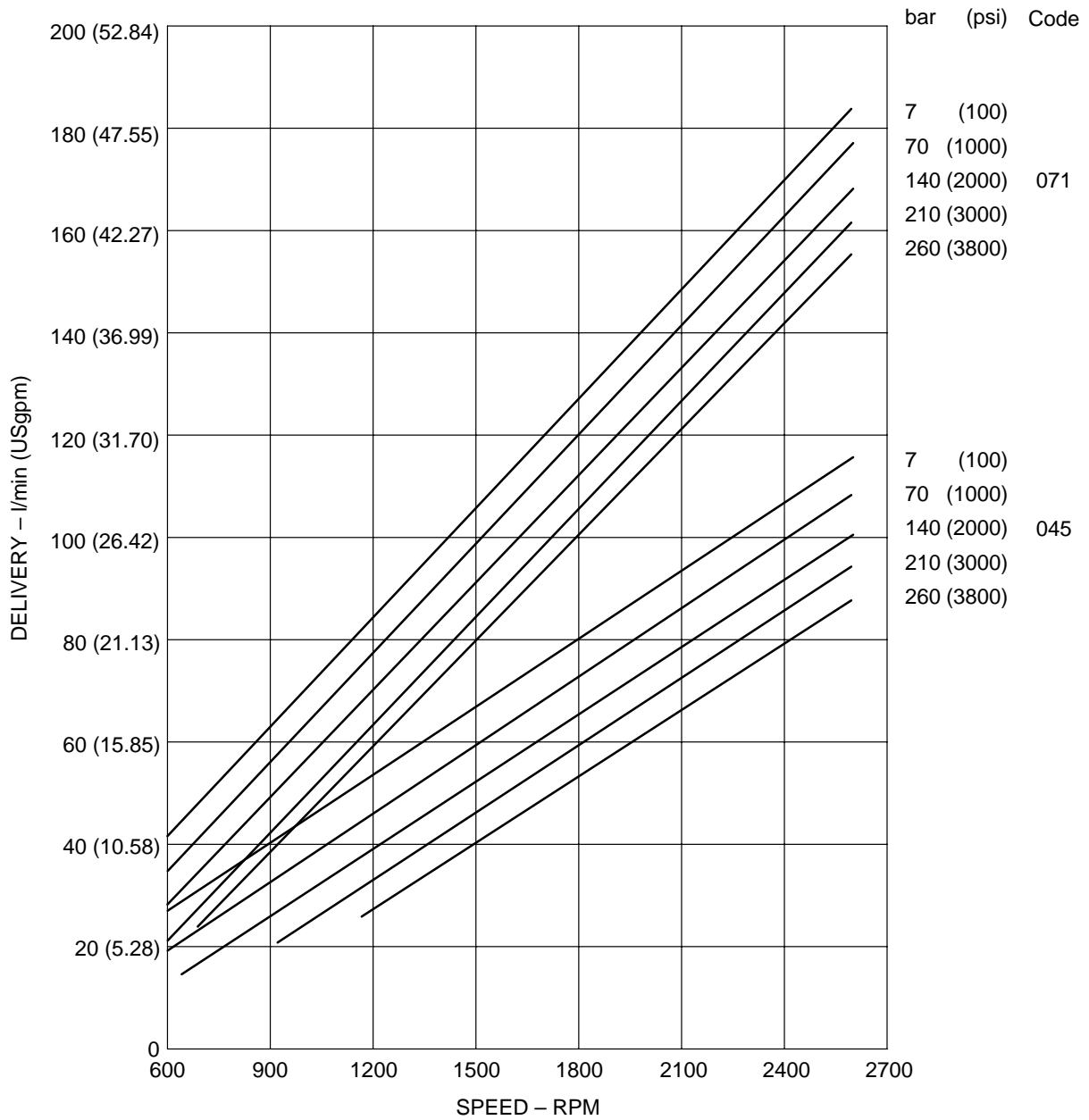

# 25VMQ (Mobile) Typical Delivery

Delivery of Code 063 and 040 Displacement Cartridges  
at 180°F, SAE 10W Oil, 0 psig Inlet

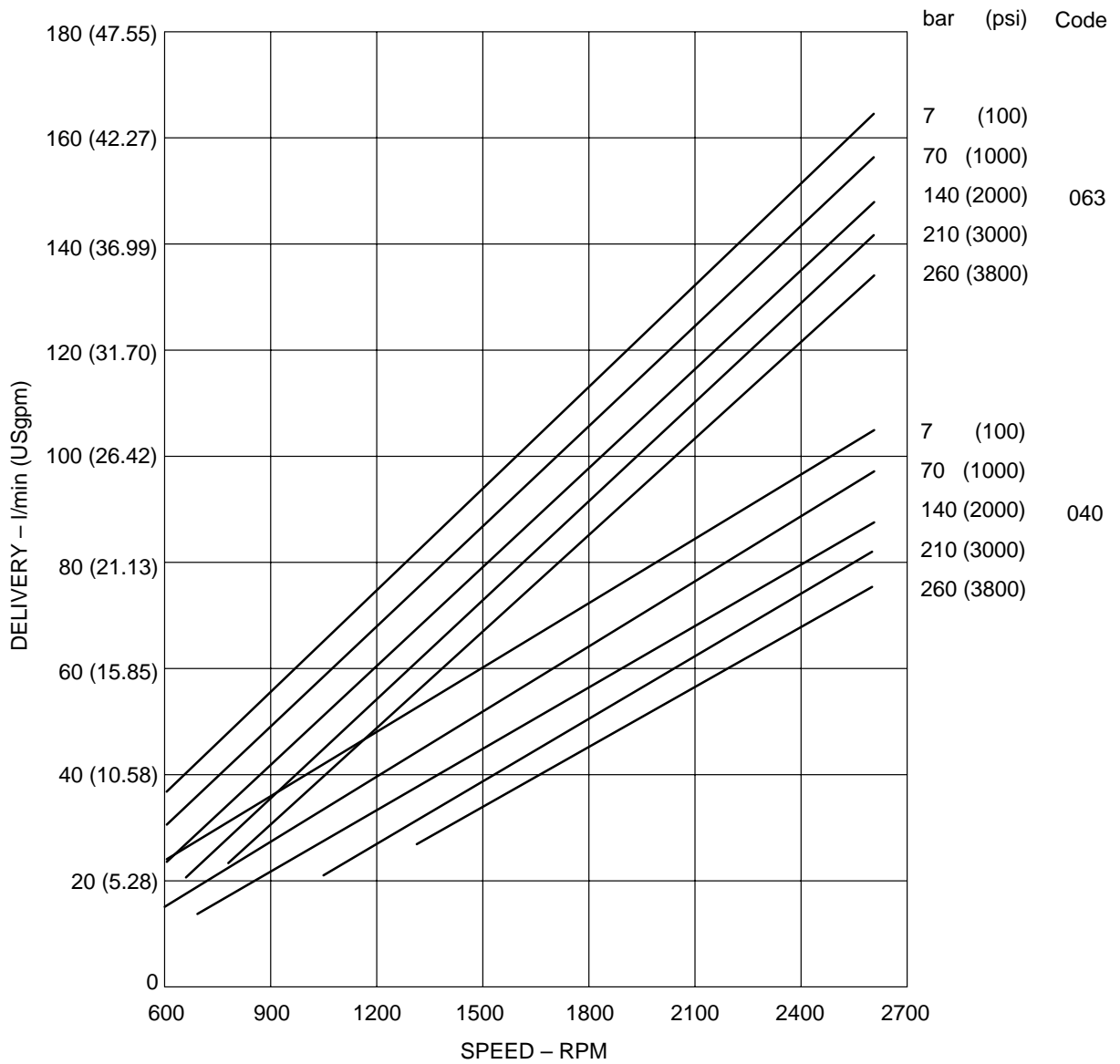

# 25VMQ (Mobile) Typical Input Power

Input Power of Code 032 and 020 Displacement Cartridges  
at 180°F, SAE 10W Oil, 0 psig Inlet

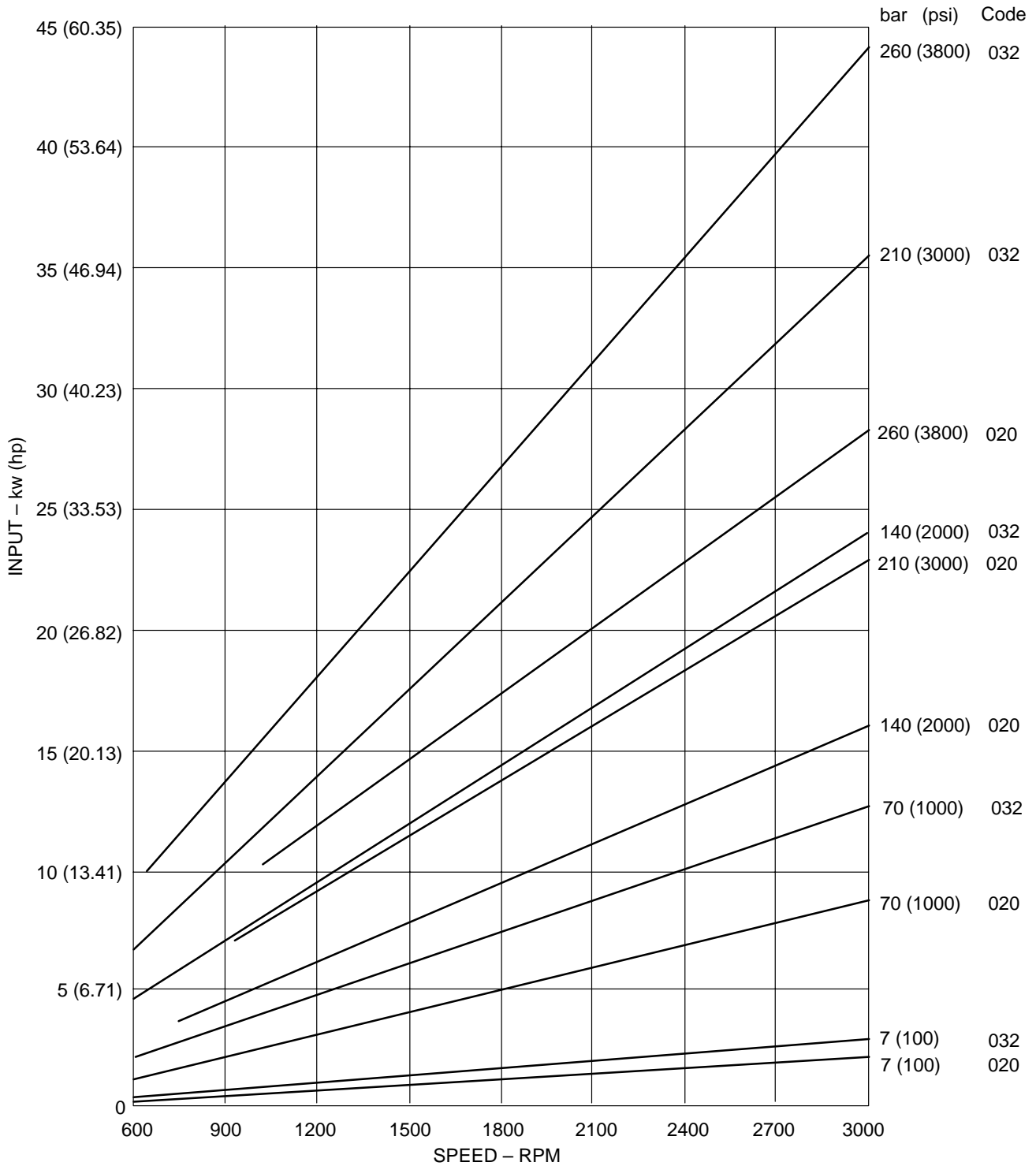

# 25VMQ (Mobile) Typical Input Power

Input Power of Code 025, 016, and 010 Displacement Cartridges  
at 180°F, SAE 10W Oil, 0 psig Inlet

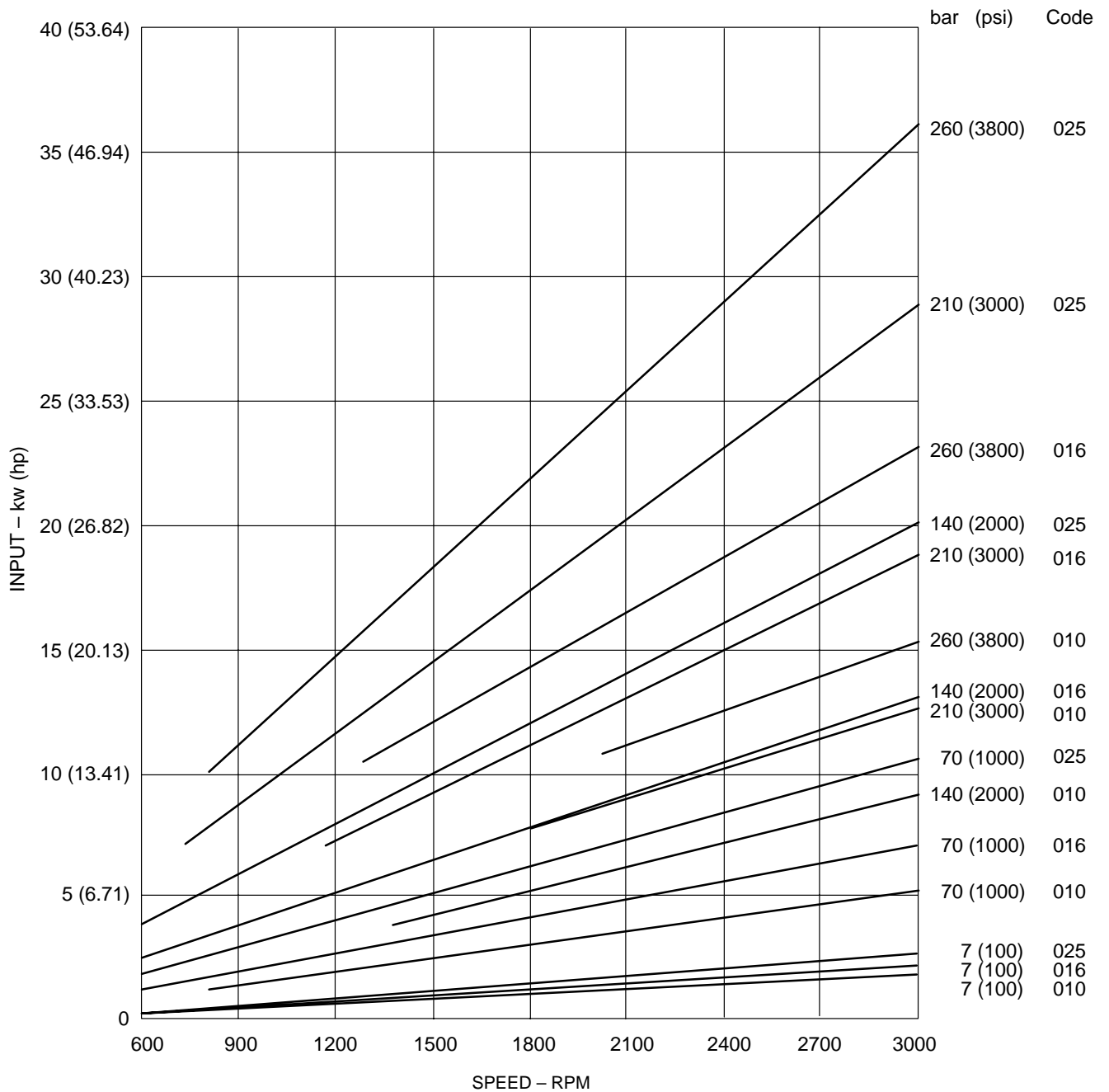

# 25VMQ (Mobile) Typical Input Power

Input Power of Code 080 and 050 Displacement Cartridges  
at 180°F, SAE 10W Oil, 0 psig Inlet

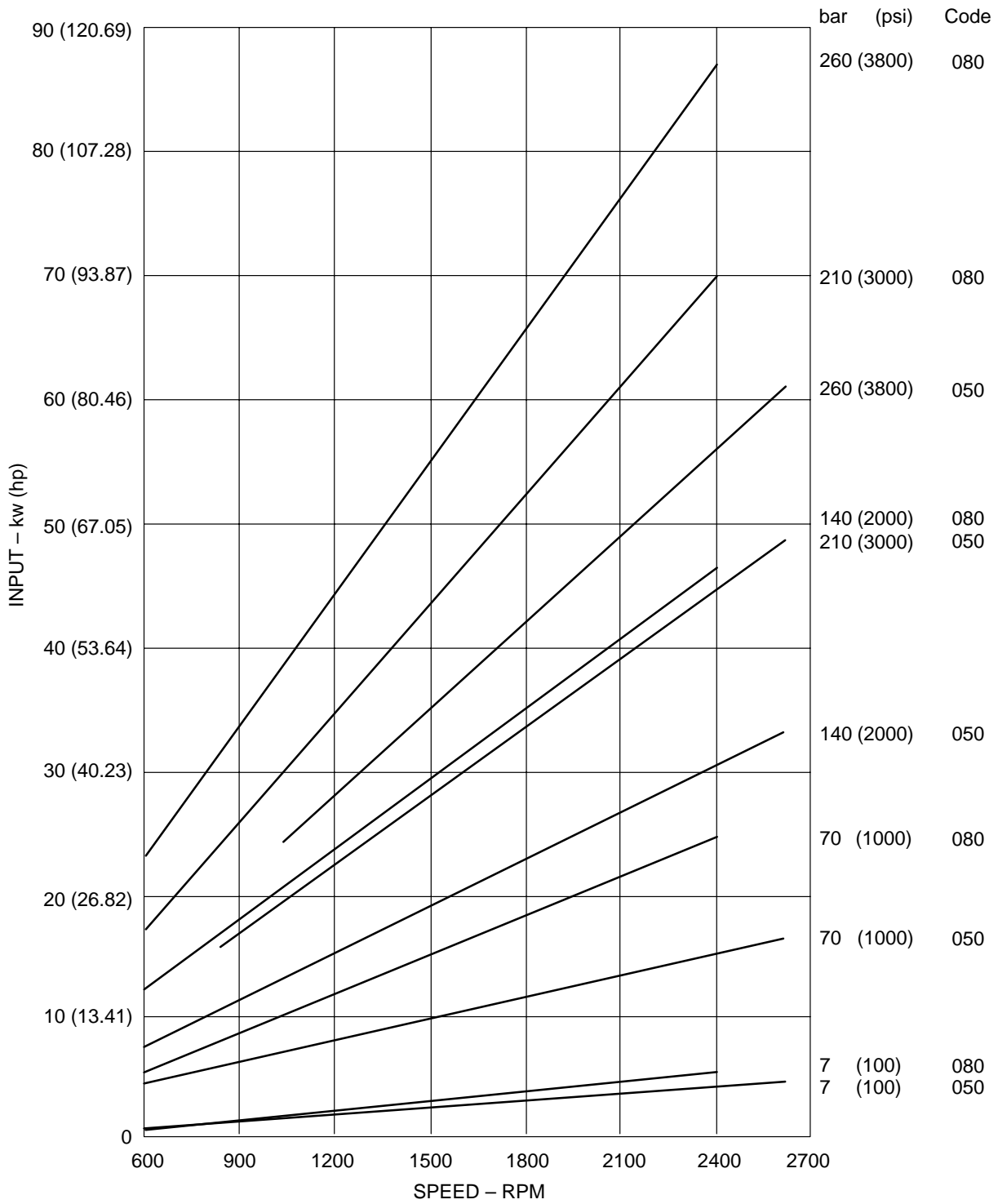

# 25VMQ (Mobile) Typical Input Power

Input Power of Code 071 and 045 Displacement Cartridges  
at 180°F, SAE 10W Oil, 0 psig Inlet

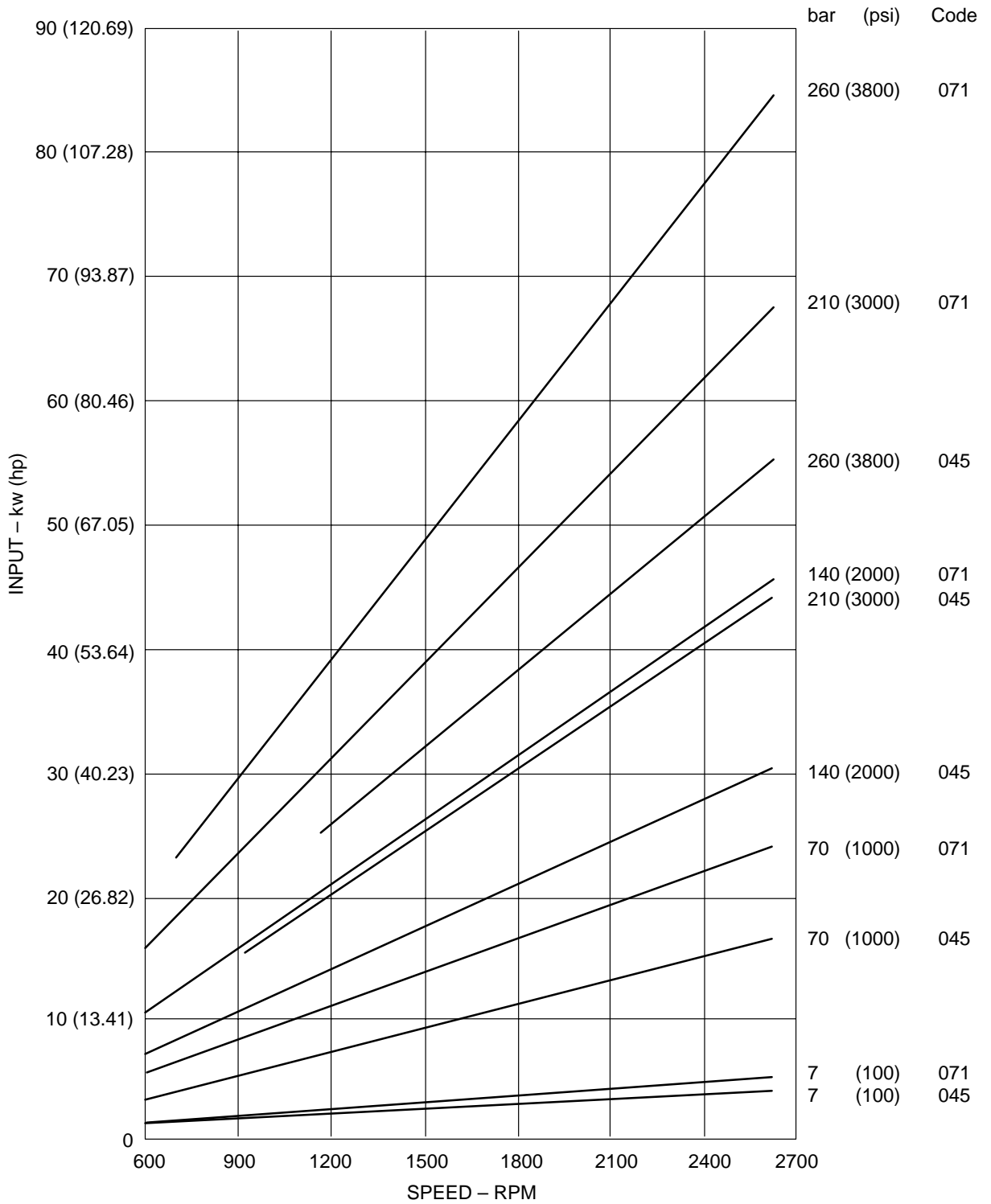

# 25VMQ (Mobile) Typical Input Power

Input Power of Code 063 and 040 Displacement Cartridges  
at 180°F, SAE 10W Oil, 0 psig Inlet

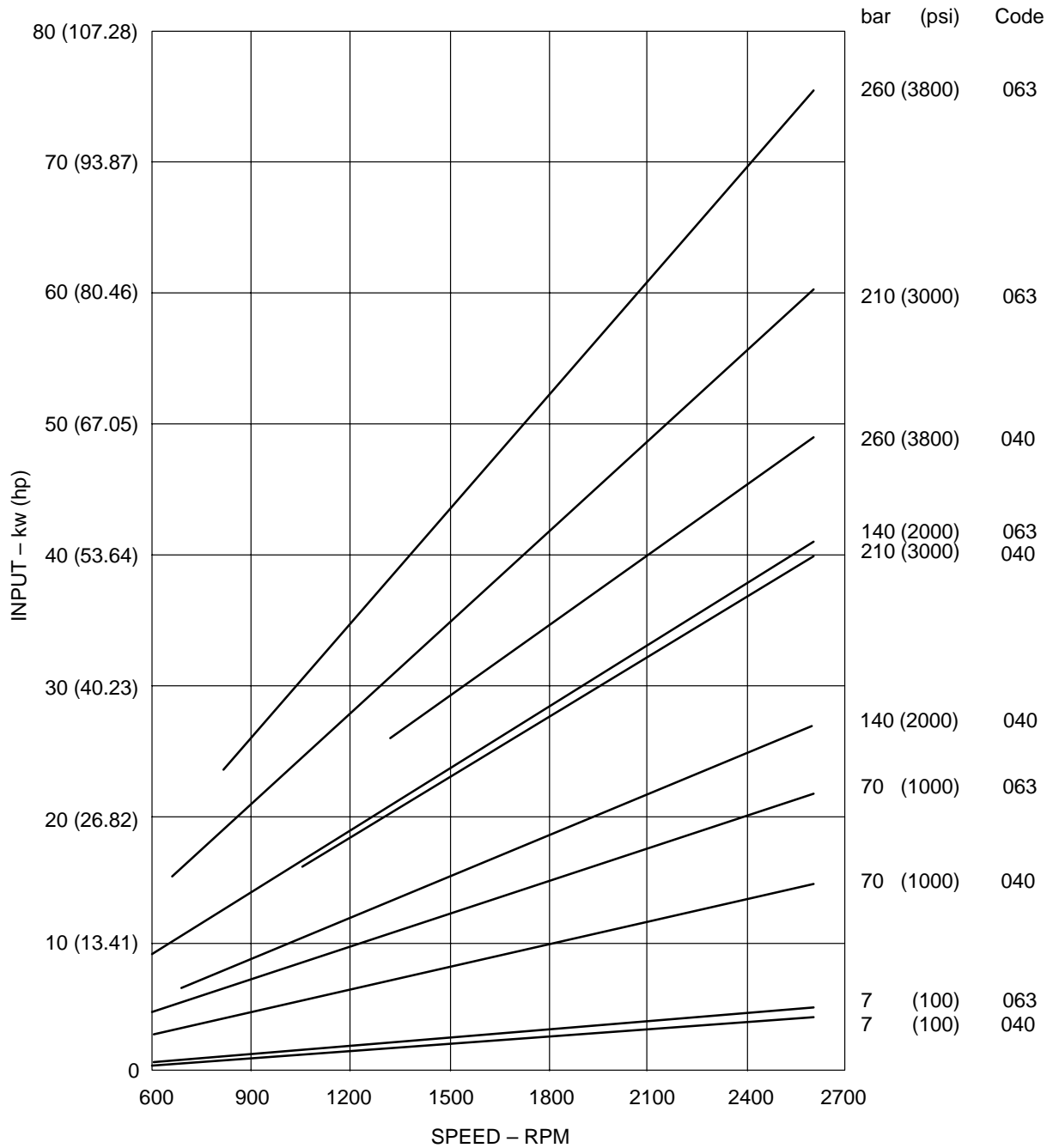

# 25VMQ Installation Dimensions

Millimeters (inches)

For shaft dimensions, see page A.78.

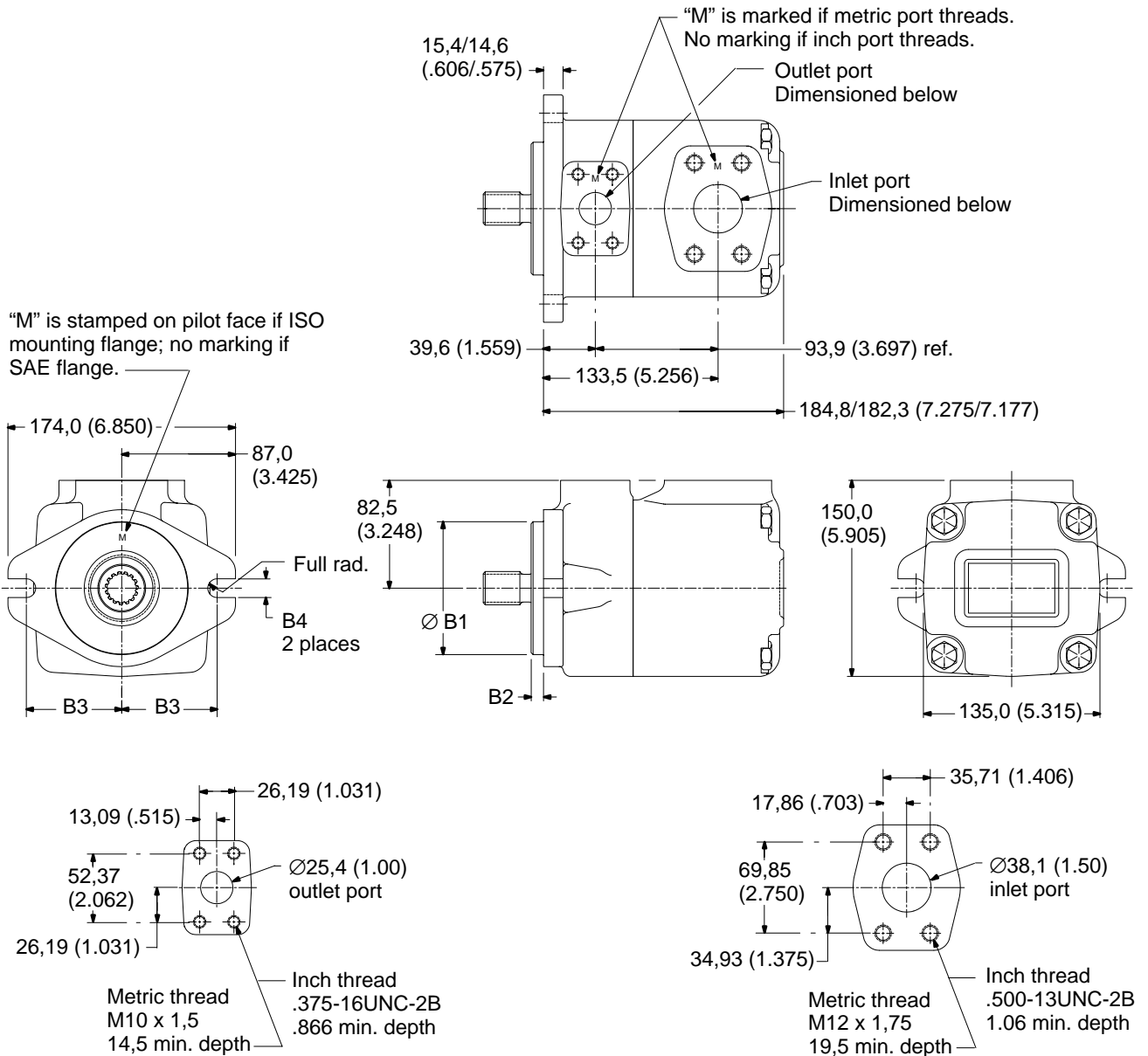

Flange Type	Ø B1	B2	B3	B4
SAE 101-2	101,60/101,55 (4.000/3.998)	9,70/9,19 (0.382/0.362)	73,00 (2.874)	14,55/14,17 (0.572/0.557)
ISO 3019/2 100A2HW	100,00/99,946 (3.937/3.935)	9,50/9,00 (0.374/0.354)	70,00 (2.756)	14,27/14,00 (0.562/0.551)

# 35VMQ Performance Data

## Maximum Operating Pressure

230 bar (3300 psi)

## Maximum Transient Pressure (peak <0.5 sec)

250 bar (3600 psi)

## Industrial Displacement, Speed, Flow, & Power Ratings 120° F, SAE10W oil, 0 psig inlet

Ring Size Code	Maximum Geometric Displacement cm <sup>3</sup> /r (in <sup>3</sup> /r)	Maximum Operating Speed rpm	Output Flow at 1500 rpm, 210 bar (3000 psi) l/min (USgpm)	Input Power at 1500 rpm, 210 bar (3000 psi) kw (hp)	Output Flow at 1800 rpm, 210 bar (3000 psi) l/min (USgpm)	Input Power at 1800 rpm, 210 bar (3000 psi) kw (hp)
090	90 (5.49)	1800	121,8 (32.2)	50,1 (67.1)	149 (39.4)	60,0 (80.4)
100	100 (6.10)	1800	136,8 (36.2)	55,7 (74.7)	167 (44.1)	66,6 (89.4)
112	112 (6.83)	1800	154,6 (40.9)	62,3 (83.5)	189 (49.8)	74,6 (100.0)
125	125 (7.63)	1800	174,4 (46.1)	69,6 (93.3)	212 (56.0)	83,3 (112.0)
135	135 (8.24)	1800	189,4 (50.1)	75,2 (100.8)	230 (60.8)	90,0 (120.7)

Note: Do not operate at speeds, pressures, and/or viscosities where internal leakage exceeds 50% of theoretical value.; i.e., actual flow must exceed 50% of theoretical flow.

## Mobile Displacement, Speed, Flow, & Power Ratings 180° F, SAE 10W oil, 0 psig inlet

Ring Size Code	Maximum Geometric Displacement cm <sup>3</sup> /r (in <sup>3</sup> /r)	Maximum Operating Speed rpm	Output Flow at Maximum rpm, 210 bar (3000 psi) l/min (USgpm)	Input Power at Maximum rpm, 210 bar (3000 psi) kw (hp)
090	90 (5.49)	2400	188,6 (49.9)	79,9 (107.1)
100	100 (6.10)	2400	212,4 (56.2)	89,0 (119.4)
112	112 (6.83)	2400	241,2 (63.8)	99,5 (133.4)
125	125 (7.63)	2400	272,6 (72.0)	111,0 (148.9)
135	135 (8.24)	2200	270 (71.4)	110,2 (147.7)

Note: Do not operate at speeds, pressures, and/or viscosities where internal leakage exceeds 50% of theoretical value.; i.e., actual flow must exceed 50% of theoretical flow.

## 35VMQ (Industrial) Sound Data 120° F, SAE 10W oil, 0 psig inlet

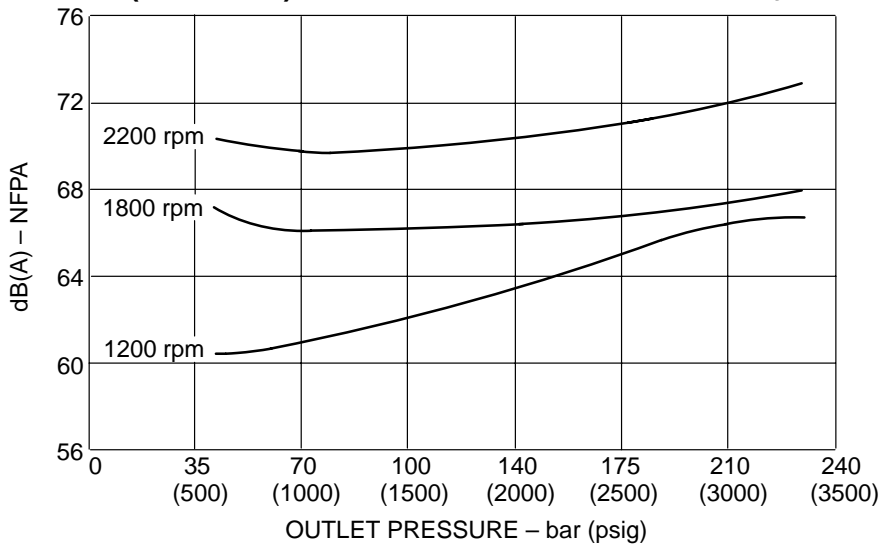

# 35VMQ Model Code

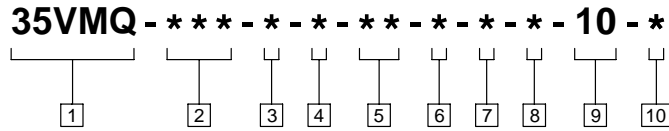

**1 Series designation (frame size)**

35VMQ – 90 to 135 cm<sup>3</sup>/r  
(5.49 to 8.24 in<sup>3</sup>/r)

**2 Displacement**

- 090 – 90 cm<sup>3</sup>/r (5.49 in<sup>3</sup>/r)
- 100 – 100 cm<sup>3</sup>/r (6.10 in<sup>3</sup>/r)
- 112 – 112 cm<sup>3</sup>/r (6.83 in<sup>3</sup>/r)
- 125 – 125 cm<sup>3</sup>/r (7.63 in<sup>3</sup>/r)
- 135 – 135 cm<sup>3</sup>/r (8.24 in<sup>3</sup>/r)

**3 Port connection**

- A – SAE 4-bolt flange (SAE J518)
- B – Metric 4-bolt flange (ISO 6162)

**4 Flange mounting style**

- A – SAE J744 127–2 (SAE C)
- B – ISO 3019/2 125A2HW

**5 Shaft end**

- 01 – SAE J744 32–1  
(1.25 in keyed shaft)
- 02 – SAE J744 32–4  
(C splined shaft)
- 03 – ISO 3019/2 E32N  
(32mm keyed shaft)
- 05 – SAE J744 38–1  
(1.50 in keyed shaft)
- 06 – SAE J744 38–4  
(C–C splined shaft)
- 07 – ISO 3019/2 E40N  
(40mm keyed shaft)

**6 Shaft seal**

- A – Single, primary
- B – Double, secondary (spring side out)
- C – Double, secondary (spring side in)

**7 Seal type**

- N – Standard, buna N
- V – Viton
- W – Buna N with Viton shaft seals

**8 Outlet port position  
(viewed from cover end)**

- A – Outlet port opposite inlet port
- B – Outlet port 90° counterclockwise from inlet port
- C – Outlet port inline with inlet port
- D – Outlet port 90° clockwise from inlet port

**9 Design level**

Subject to change. Dimensions remain the same for designs 10 through 19.

**10 Rotation  
(viewed from shaft end)**

- R – Right hand (clockwise)
- L – Left hand (counterclockwise)

# 35VMQ (Industrial) Typical Delivery

Delivery of Code 135 and 100 Displacement Cartridges  
 at 120° F, SAE 10W Oil, 0 psig Inlet

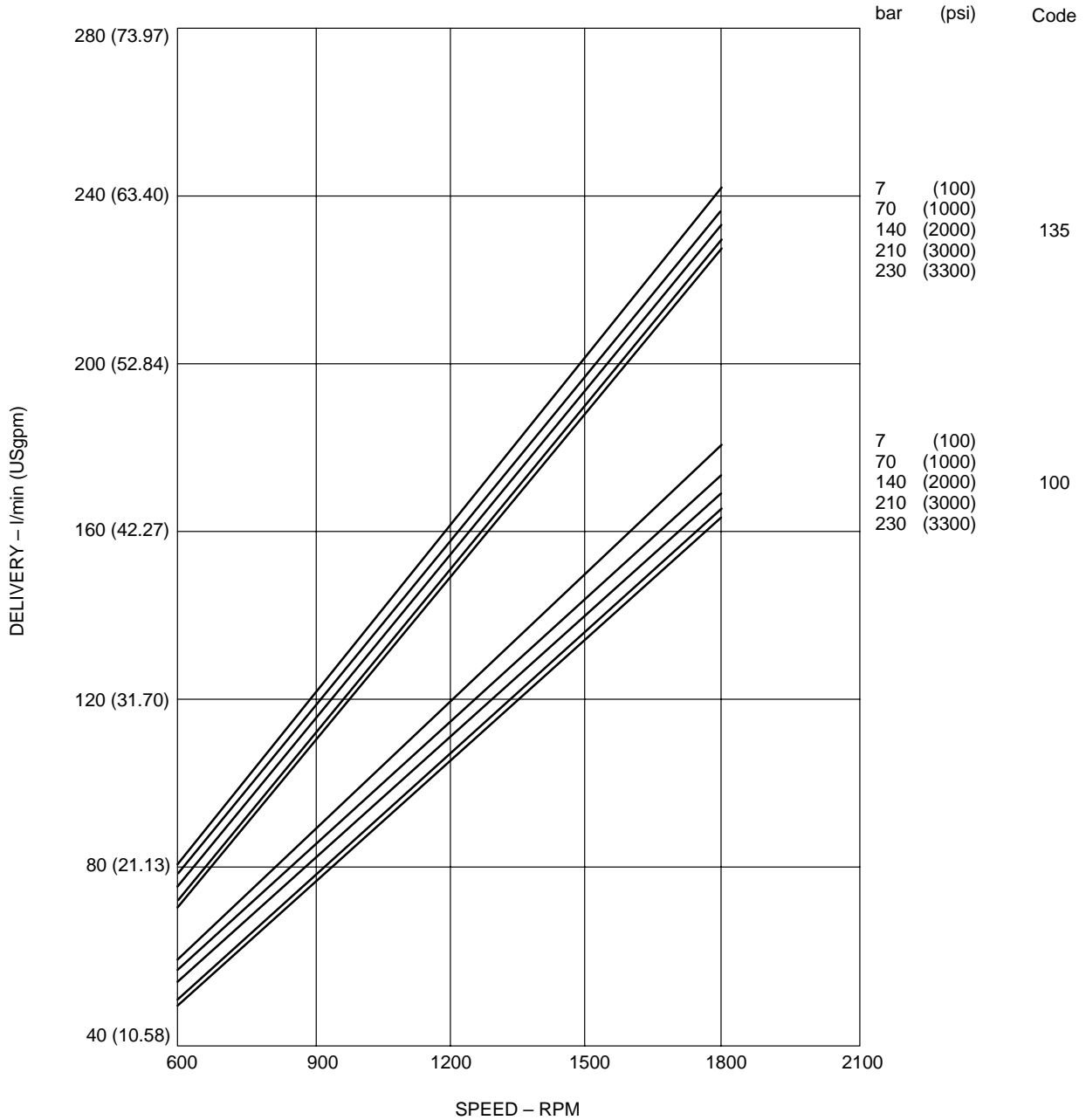

# 35VMQ (Industrial) Typical Delivery

Delivery of Code 125 and 090 Displacement Cartridges  
at 120° F, SAE 10W Oil, 0 psig Inlet

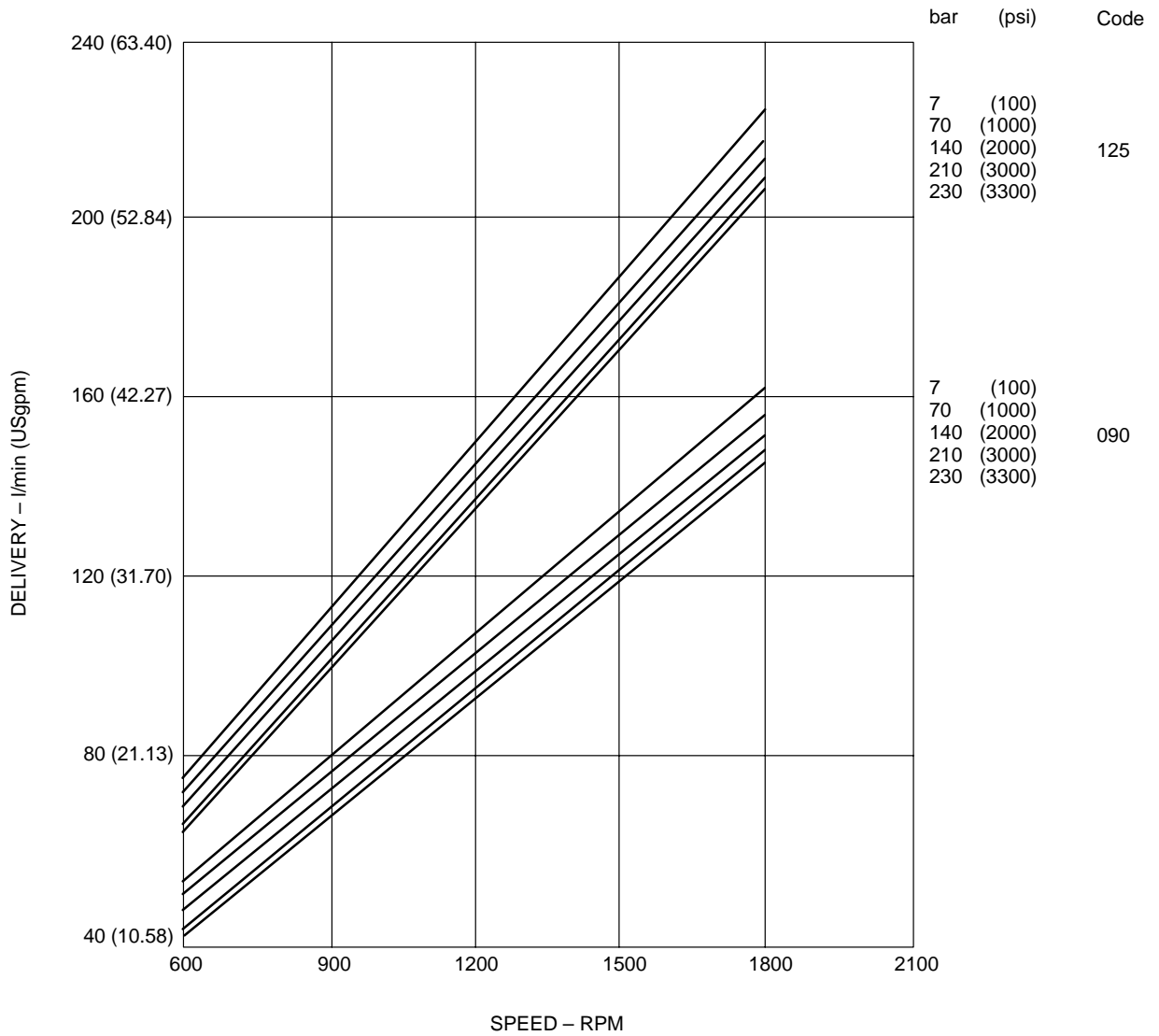

# 35VMQ (Industrial) Typical Delivery

Delivery of Code 112 Displacement Cartridge  
at 120° F, SAE 10W Oil, 0 psig Inlet

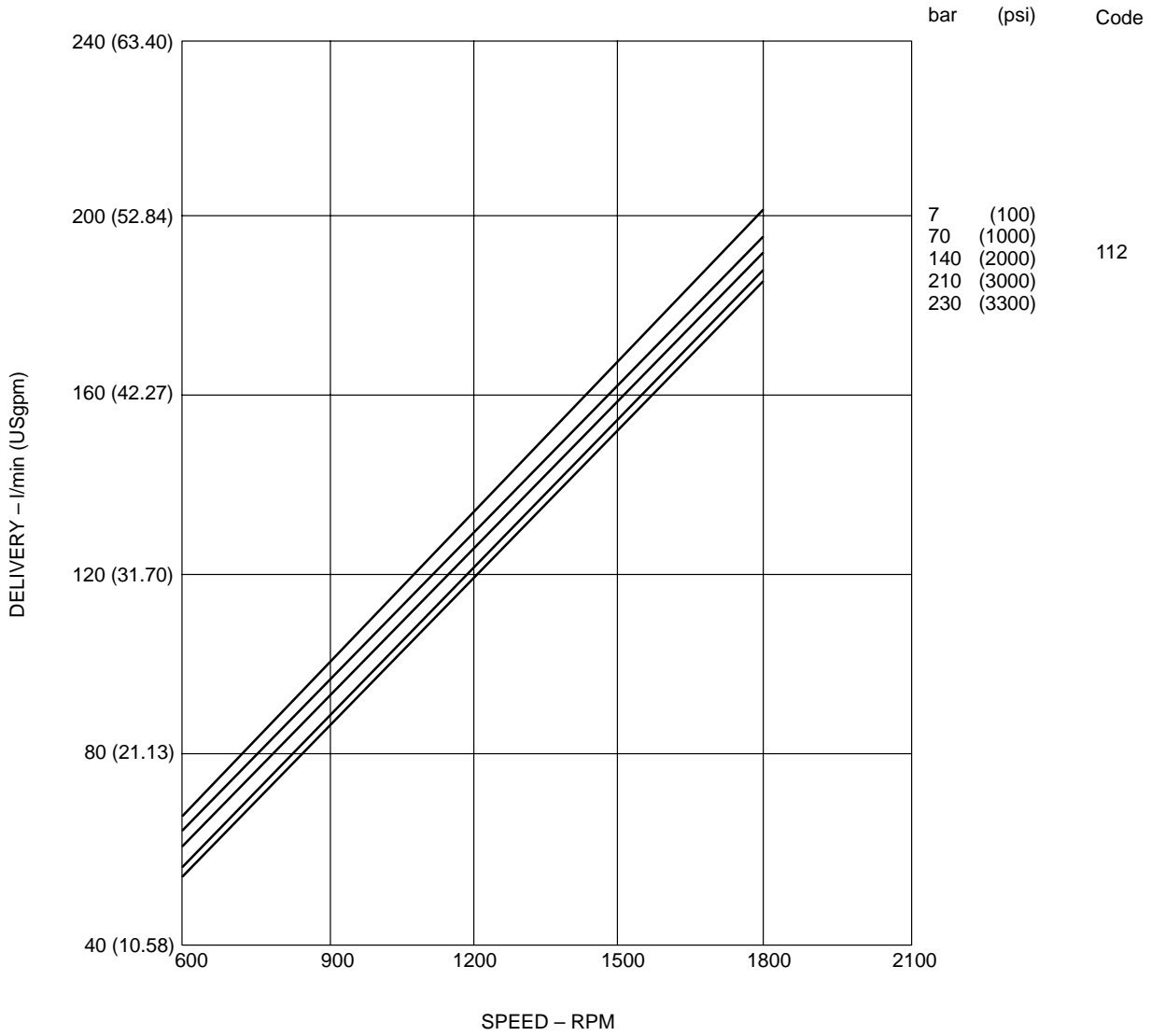

# 35VMQ (Industrial) Typical Input Power

Input Power of Code 135 and 100 Displacement Cartridges  
at 120° F, SAE 10W Oil, 0 psig Inlet

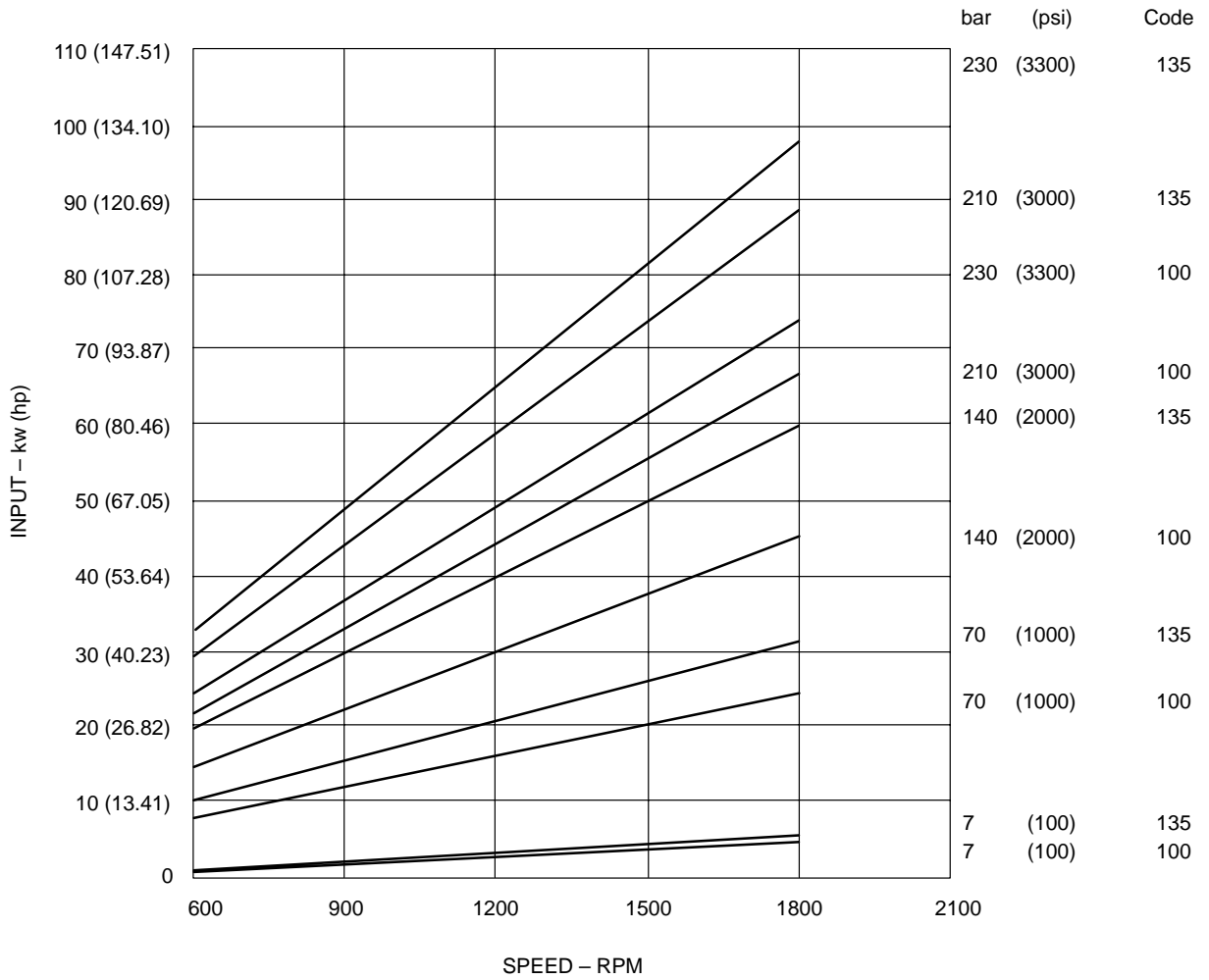

# 35VMQ (Industrial) Typical Input Power

Input Power of Code 125 and 090 Displacement Cartridges  
at 120° F, SAE 10W Oil, 0 psig Inlet

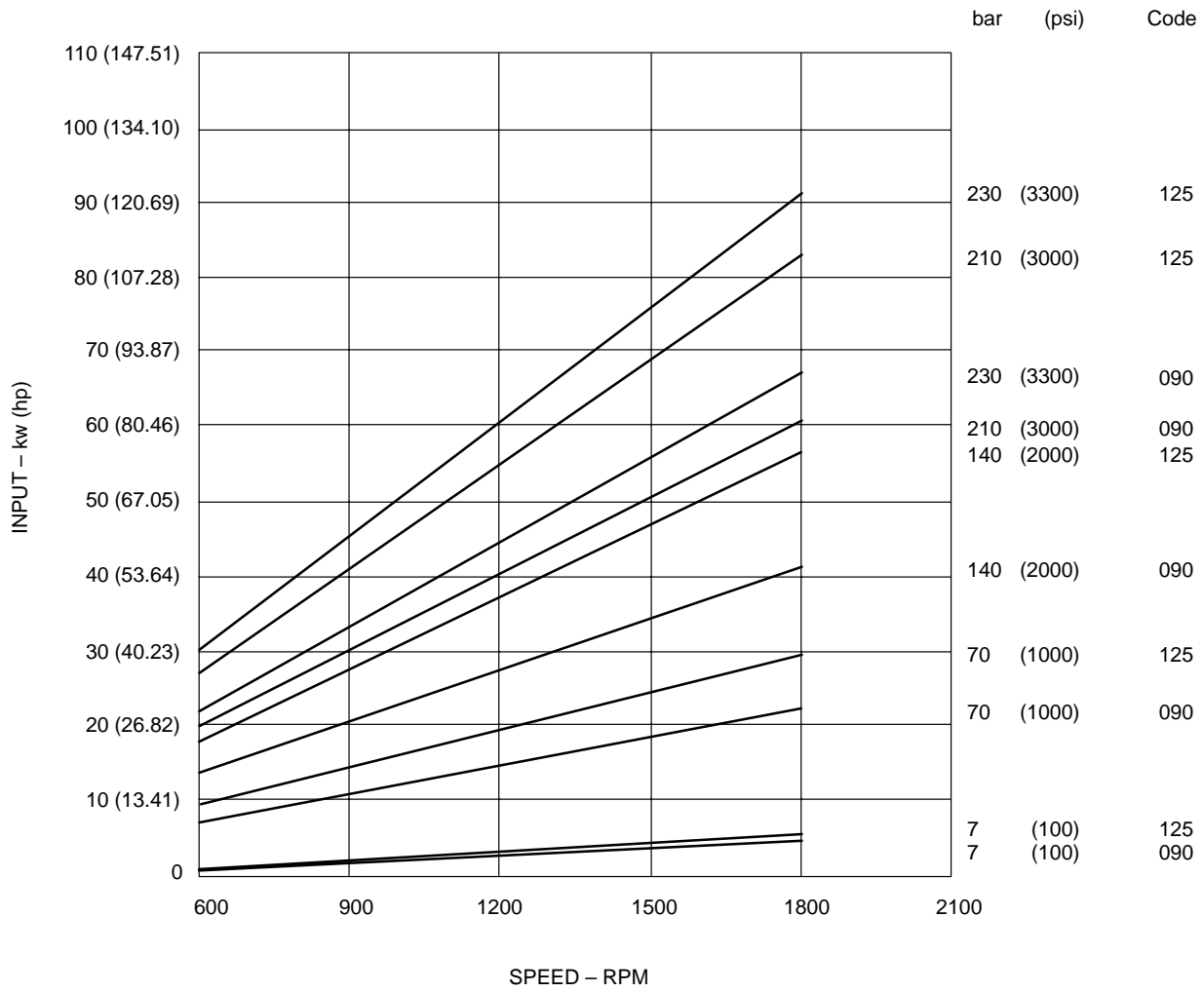

# 35VMQ (Industrial) Typical Input Power

Input Power of Code 112 Displacement Cartridge  
at 120° F, SAE 10W Oil, 0 psig Inlet

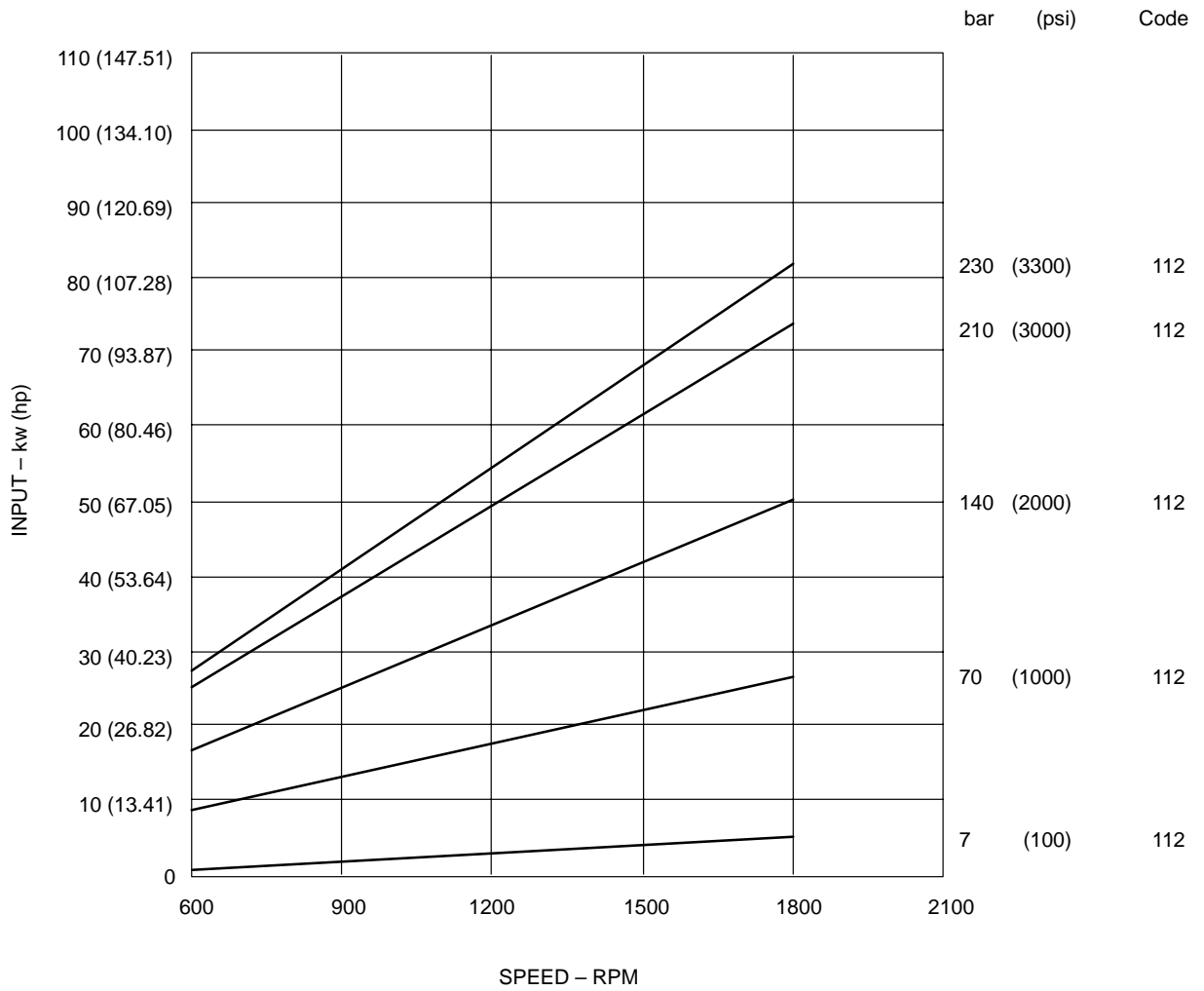

# 35VMQ (Mobile) Typical Delivery

Delivery of Code 135 and 100 Displacement Cartridges  
at 180° F, SAE 10W Oil, 0 psig Inlet

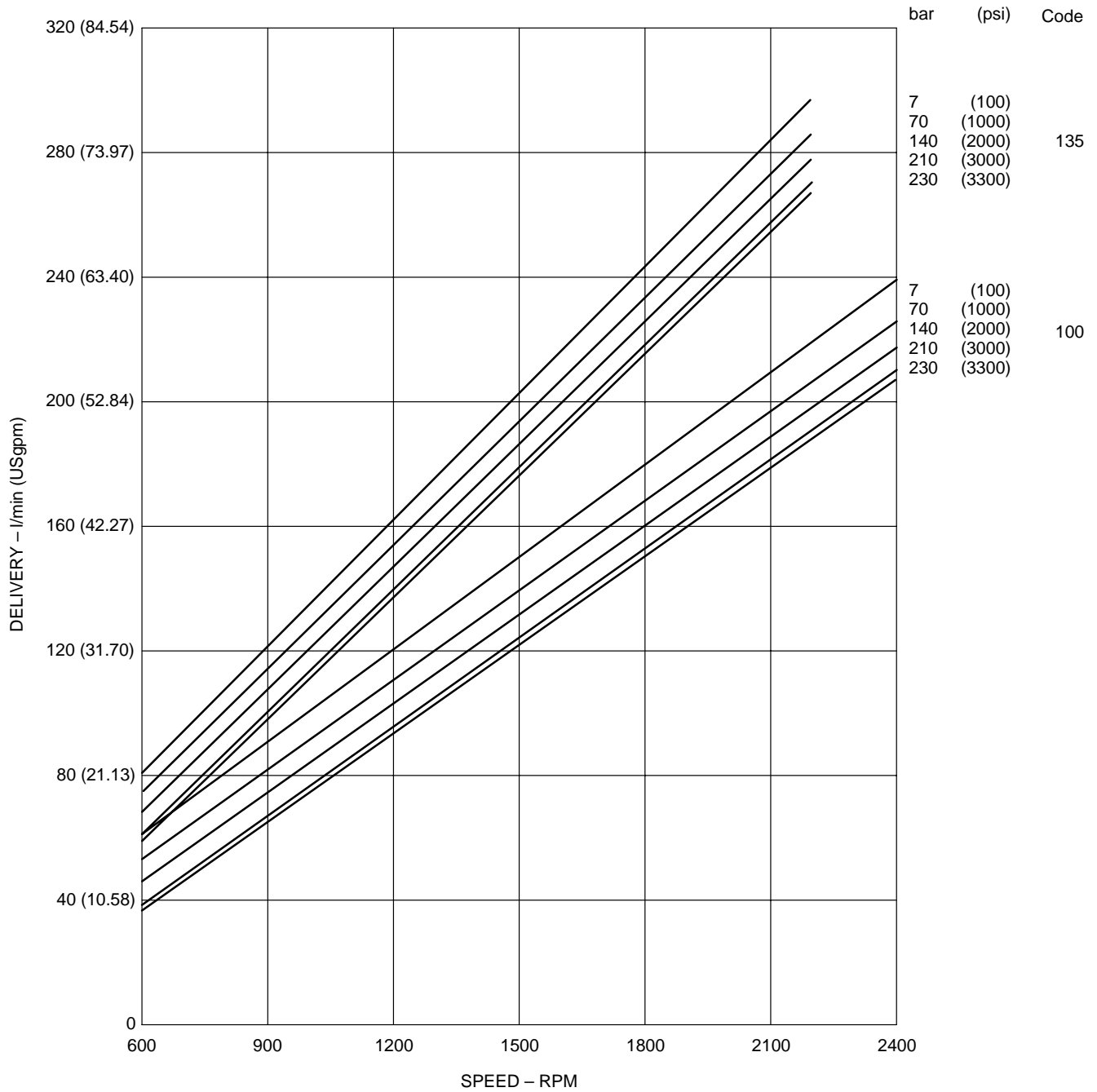

# 35VMQ (Mobile) Typical Delivery

Delivery of Code 125 and 090 Displacement Cartridges  
at 180° F, SAE 10W Oil, 0 psig Inlet

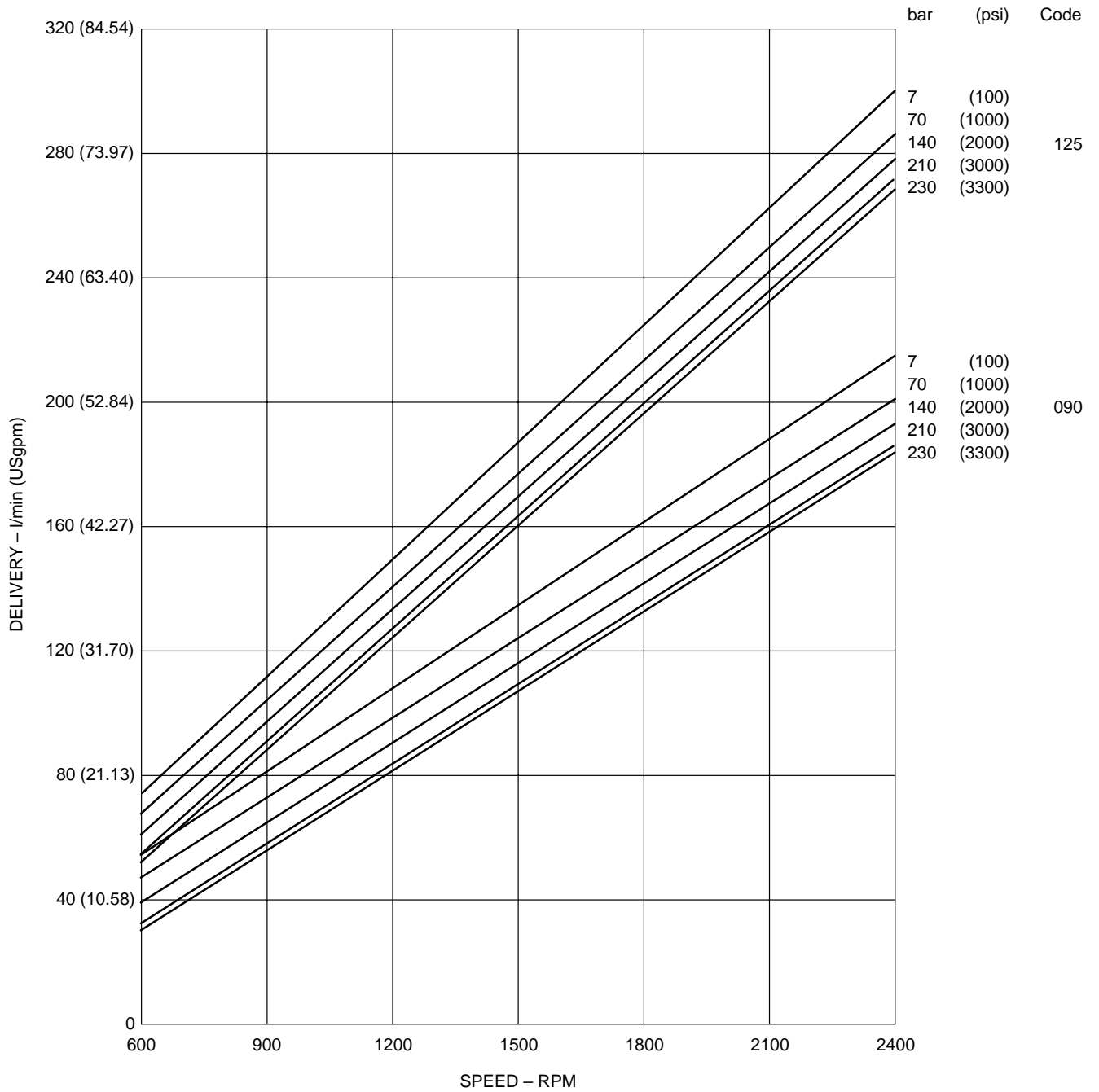

# 35VMQ (Mobile) Typical Delivery

**Delivery of Code 112 Displacement Cartridge  
at 180° F, SAE 10W Oil, 0 psig Inlet**

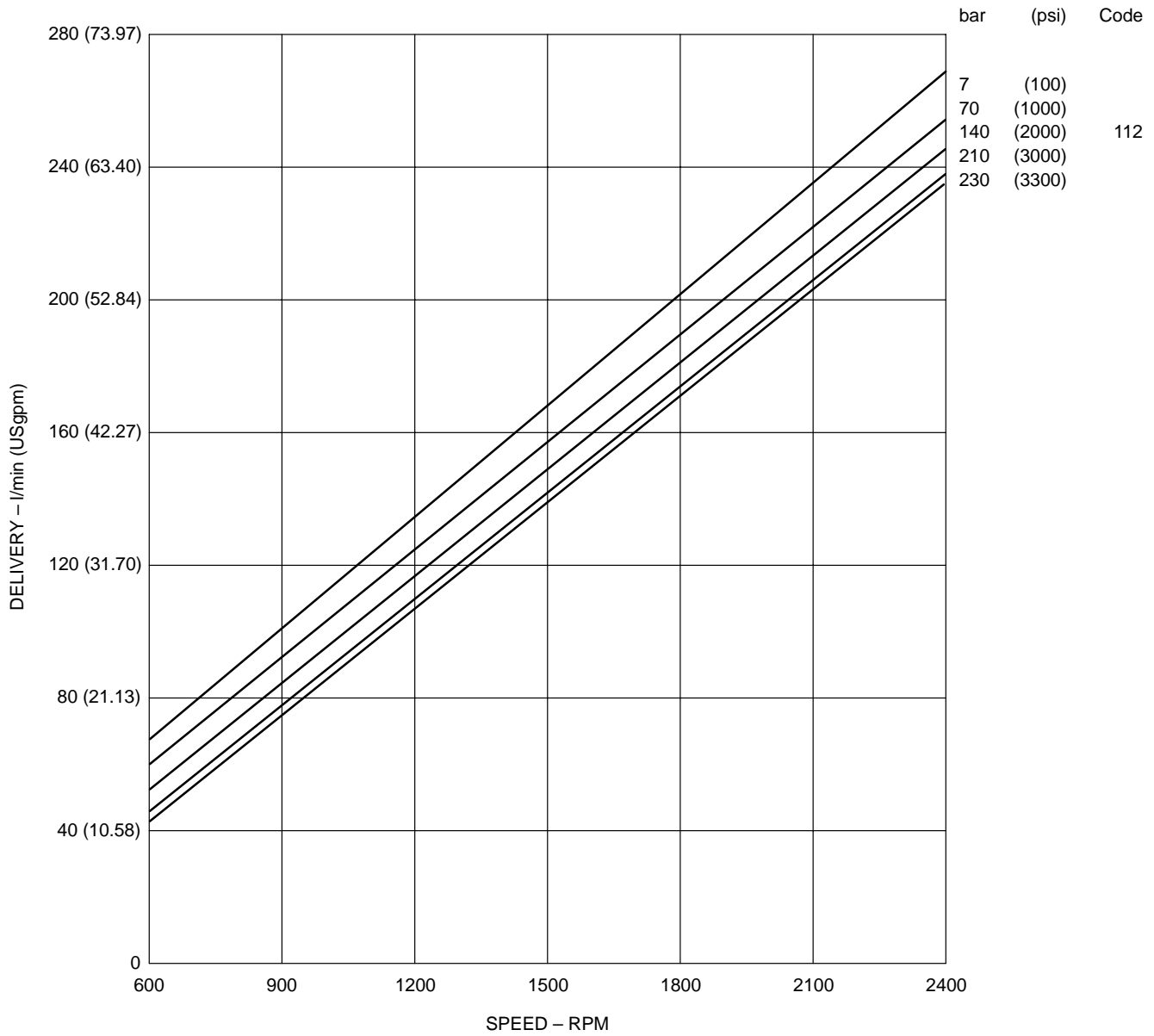

# 35VMQ (Mobile) Typical Input Power

Input Power of Code 135 and 100 Displacement Cartridges  
at 180° F, SAE 10W Oil, 0 psig Inlet

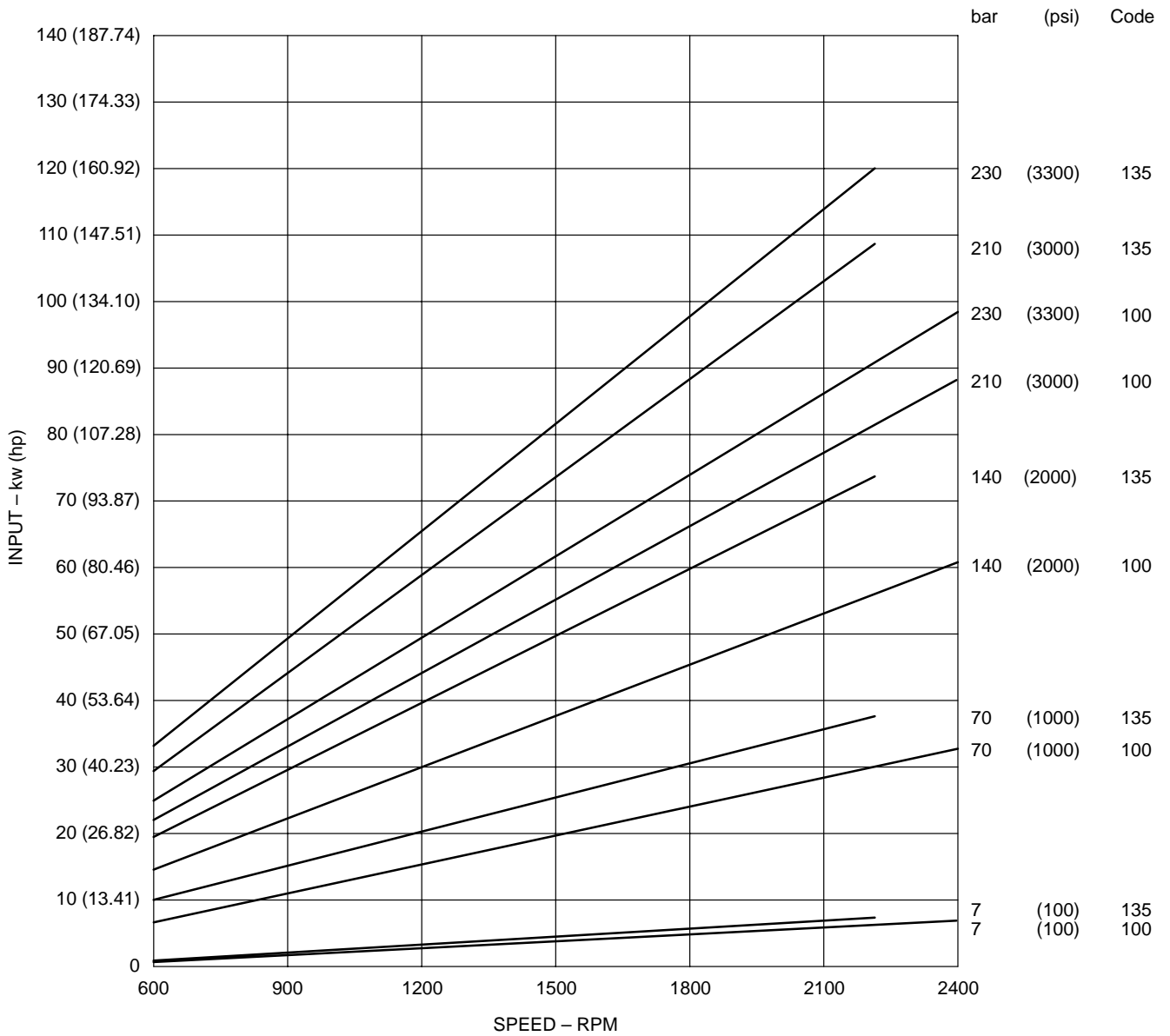

# 35VMQ (Mobile) Typical Input Power

Input Power of Code 125 and 090 Displacement Cartridges  
at 180° F, SAE 10W Oil, 0 psig Inlet

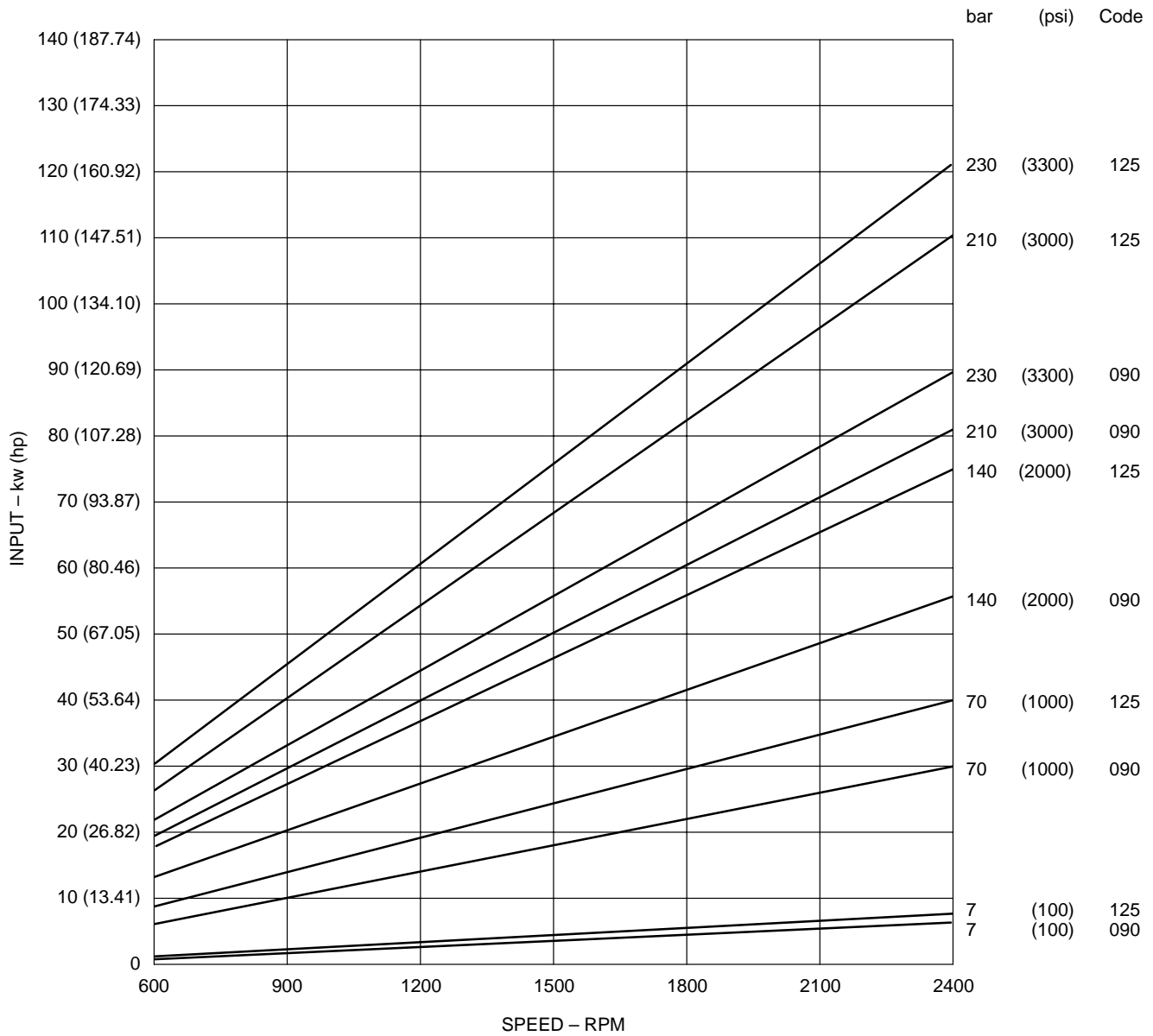

# 35VMQ (Mobile) Typical Input Power

**Input Power of Code 112 Displacement Cartridge  
at 180° F, SAE 10W Oil, 0 psig Inlet**

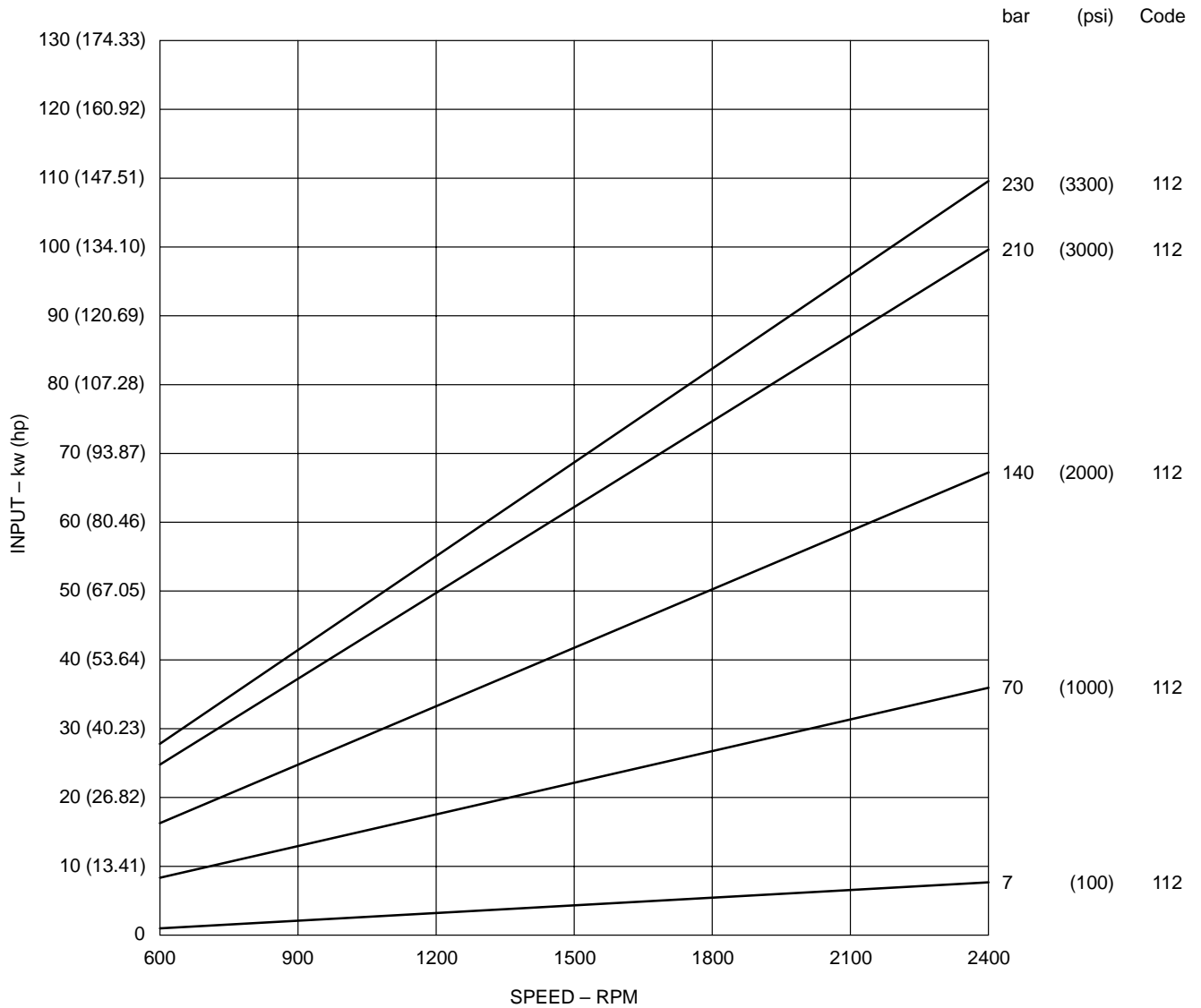

# 35VMQ Installation Dimensions

Millimeters (inches)

For shaft dimensions, see page A.79.

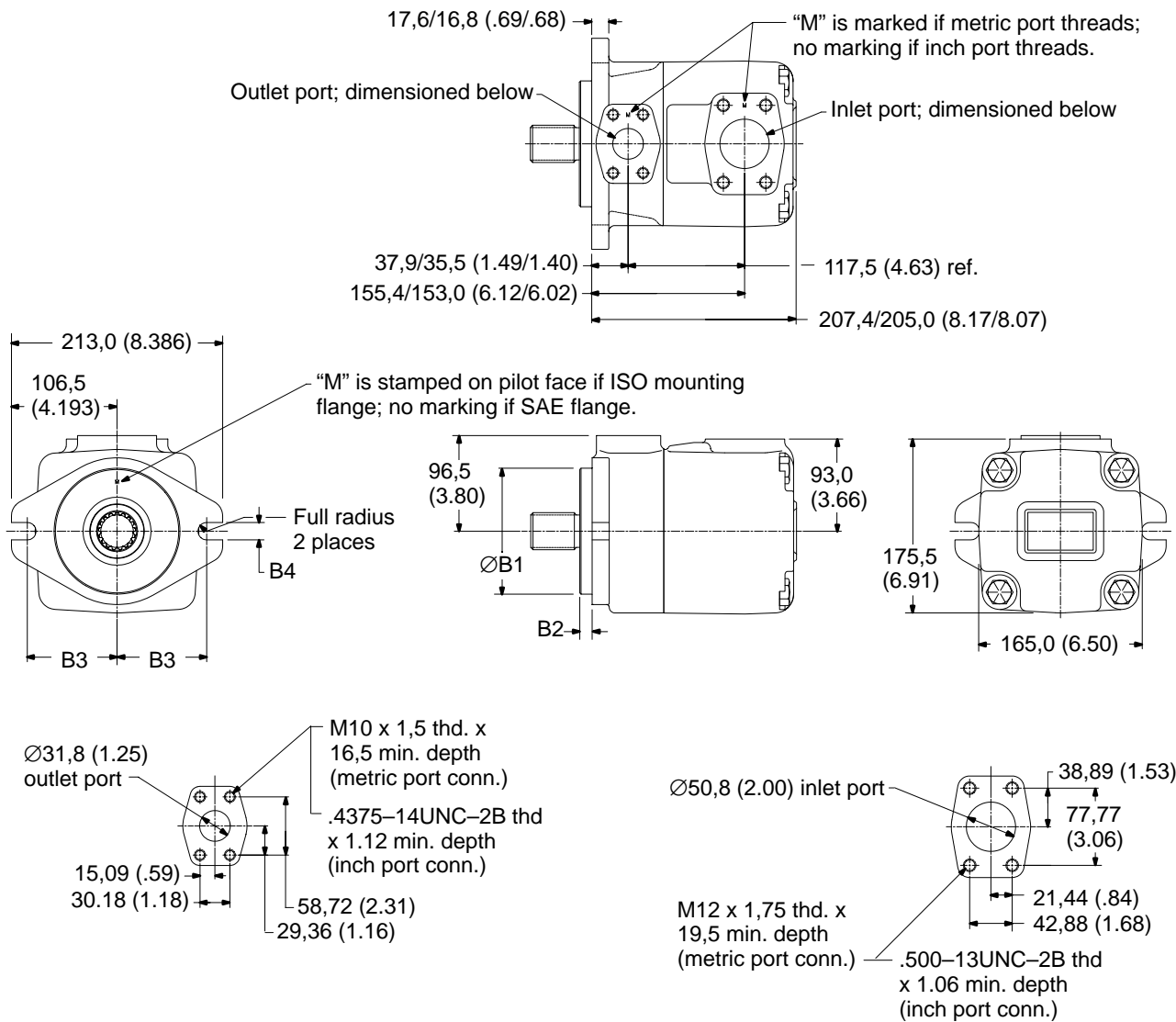

Flange Type	Ø B1	B2	B3	B4
SAE 127-2	127,00/126,95 (5.000/4.998)	12,70/12,19 (0.500/0.480)	90,50 (3.563)	17,75/17,37 (0.698/0.683)
ISO 3019/2 125A2HW	125,000/124,937 (4.921/4.918)	9,50/9,00 (0.374/0.354)	90,00 (3.543)	18,27/18,00 (0.719/0.709)

# 2525VMQ Typical Performance Data

## Maximum Operating Pressure

260 bar (3800 psi)

## Maximum Transient Pressure (peak < 0.5 sec)

290 bar (4200 psi)

## Industrial Displacement, Speed, Flow, and Power Ratings 120° F, SAE 10W oil, 0 psig inlet

Ring Size Code	Maximum Geometric Displacement cm <sup>3</sup> /r (in <sup>3</sup> /r)	Maximum Operating Speed rpm	Output Flow at 1500 rpm, 210 bar (3000 psi) l/min (USgpm)	Input Power at 1500 rpm, 210 bar (3000 psi) kw (hp)	Output Flow at 1800 rpm, 210 bar (3000 psi) l/min (USgpm)	Input Power at 1800 rpm, 210 bar (3000 psi) kw (hp)
010	10 (0.62)	1800	11,39 (3.01)	6,24 (8.37)	14,7 (3.88)	7,55 (10.12)
016	16 (0.98)	1800	20,24 (5.35)	9,29 (12.46)	25,32 (6.69)	11,21 (15.03)
020	20 (1.23)	1800	26,38 (6.97)	11,41 (15.30)	32,70 (8.64)	13,75 (18.44)
025	25 (1.58)	1800	34,98 (9.24)	14,37 (19.28)	43,02 (11.37)	17,31 (23.21)
032	32 (1.96)	1800	44,32 (11.71)	17,59 (23.59)	54,23 (14.33)	21,17 (28.39)
040	40 (2.44)	1800	50,14 (13.25)	22,88 (30.68)	61,74 (16.31)	27,46 (36.82)
045	45 (2.75)	1800	57,63 (15.23)	25,46 (34.14)	70,74 (18.69)	30,56 (40.98)
050	50 (3.05)	1800	65,13 (17.21)	28,04 (37.61)	79,73 (21.07)	33,66 (45.14)
063	63 (3.84)	1800	84,55 (22.34)	34,74 (46.58)	103,03 (27.22)	41,69 (55.91)
071	71 (4.33)	1800	96,59 (25.52)	38,89 (52.15)	117,48 (31.04)	46,67 (62.59)
080	80 (4.88)	1800	110,11 (29.09)	43,55 (58.40)	133,71 (35.33)	52,26 (70.09)

Note: Do not operate at speeds, pressures, and/or viscosities where internal leakage exceeds 50% of theoretical value.; i.e., actual flow must exceed 50% of theoretical flow. Maximum speed rating for double pumps is limited to lowest speed rating of cartridges contained therein.

## Mobile Displacement, Speed, Flow, and Power Ratings 180° F, SAE 10W oil, 0 psig inlet

Ring Size Code	Maximum Geometric Displacement cm <sup>3</sup> /r (in <sup>3</sup> /r)	Maximum Operating Speed rpm	Output Flow at Maximum rpm, 210 bar (3000 psi) l/min (USgpm)	Input Power at Maximum rpm, 210 bar (3000 psi) kw (hp)
010	10 (0.62)	3000	22,38 (5.91)	12,92 (17.33)
016	16 (0.98)	3000	40,07 (10.59)	19,03 (25.51)
020	20 (1.23)	3000	52,36 (13.83)	23,26 (31.19)
025	25 (1.58)	3000	69,57 (18.38)	29,19 (39.15)
032	32 (1.96)	3000	88,25 (23.32)	35,63 (47.78)
040	40 (2.44)	2600	81,19 (21.45)	39,96 (53.59)
045	45 (2.75)	2600	94,18 (24.88)	44,44 (59.59)
050	50 (3.05)	2600	107,17 (28.32)	48,92 (65.60)
063	63 (3.84)	2600	140,83 (37.21)	60,52 (81.16)
071	71 (4.33)	2600	161,70 (42.72)	67,72 (90.81)
080	80 (4.88)	2400	169,43 (44.76)	69,80 (93.60)

Note: Do not operate at speeds, pressures, and/or viscosities where internal leakage exceeds 50% of theoretical value.; i.e., actual flow must exceed 50% of theoretical flow. Maximum speed rating for double pumps is limited to lowest speed rating of cartridges contained therein.

# 2525VMQ Typical Sound Data

120° F, SAE 10W oil, 0 psig inlet,  
both pump cartridges loaded

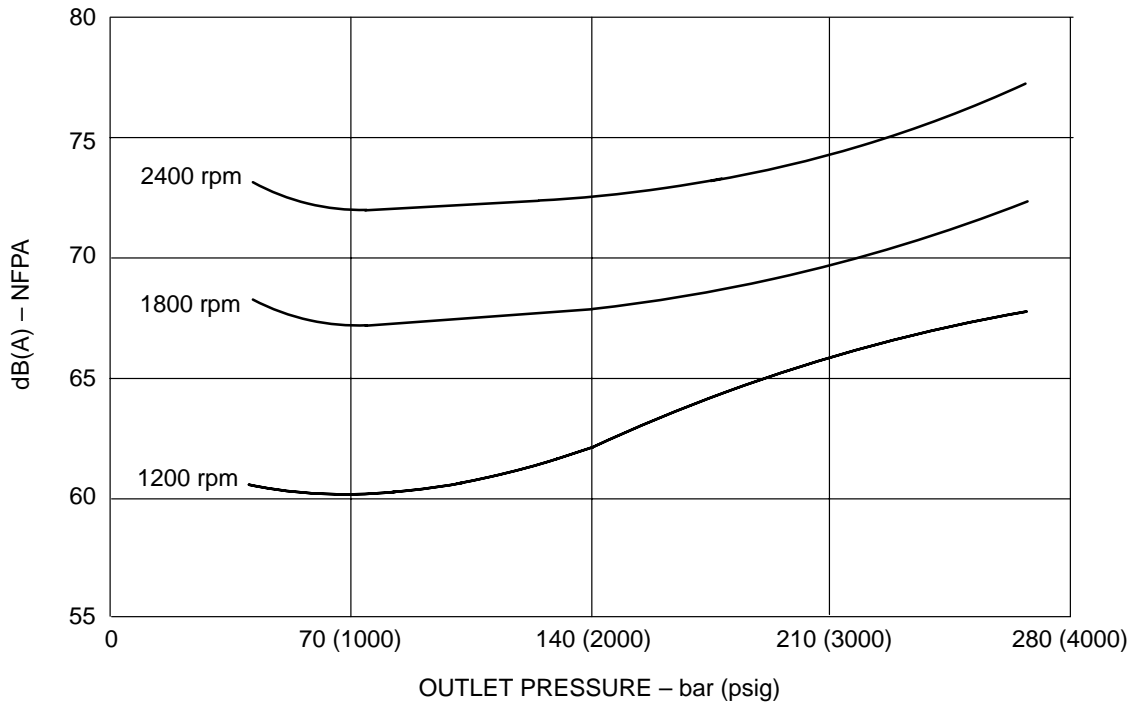

## Delivery and Input Power

2525VMQ delivery and input power can be determined from 25VMQ curves beginning on page A.33.

# 2525VMQ Model Code

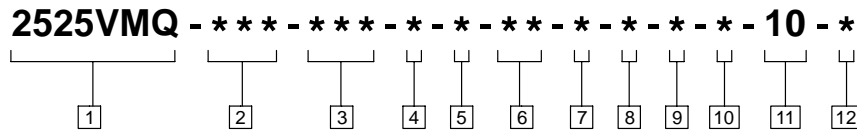

**1 Series designation (frame size)**

2525VMQ – 20 to 160 cm<sup>3</sup>/r  
(1.24 to 9.76 in<sup>3</sup>/r)

**2 Displacement – front section**

- 010 – 10 cm<sup>3</sup>/r (0.62 in<sup>3</sup>/r)
- 016 – 16 cm<sup>3</sup>/r (0.98 in<sup>3</sup>/r)
- 020 – 20 cm<sup>3</sup>/r (1.23 in<sup>3</sup>/r)
- 025 – 25 cm<sup>3</sup>/r (1.58 in<sup>3</sup>/r)
- 032 – 32 cm<sup>3</sup>/r (1.96 in<sup>3</sup>/r)
- 040 – 40 cm<sup>3</sup>/r (2.44 in<sup>3</sup>/r)
- 045 – 45 cm<sup>3</sup>/r (2.75 in<sup>3</sup>/r)
- 050 – 50 cm<sup>3</sup>/r (3.05 in<sup>3</sup>/r)
- 063 – 63 cm<sup>3</sup>/r (3.84 in<sup>3</sup>/r)
- 071 – 71 cm<sup>3</sup>/r (4.33 in<sup>3</sup>/r)
- 080 – 80 cm<sup>3</sup>/r (4.88 in<sup>3</sup>/r)

**3 Displacement – rear section**

- 010 – 10 cm<sup>3</sup>/r (0.62 in<sup>3</sup>/r)
- 016 – 16 cm<sup>3</sup>/r (0.98 in<sup>3</sup>/r)
- 020 – 20 cm<sup>3</sup>/r (1.23 in<sup>3</sup>/r)
- 025 – 25 cm<sup>3</sup>/r (1.58 in<sup>3</sup>/r)
- 032 – 32 cm<sup>3</sup>/r (1.96 in<sup>3</sup>/r)
- 040 – 40 cm<sup>3</sup>/r (2.44 in<sup>3</sup>/r)
- 045 – 45 cm<sup>3</sup>/r (2.75 in<sup>3</sup>/r)
- 050 – 50 cm<sup>3</sup>/r (3.05 in<sup>3</sup>/r)
- 063 – 63 cm<sup>3</sup>/r (3.84 in<sup>3</sup>/r)
- 071 – 71 cm<sup>3</sup>/r (4.33 in<sup>3</sup>/r)
- 080 – 80 cm<sup>3</sup>/r (4.88 in<sup>3</sup>/r)

**4 Port connection**

- A – SAE 4-bolt flange (SAE J518)
- B – Metric 4-bolt flange (ISO 6162)

**5 Flange mounting style**

- A – SAE J744 101–2 (SAE B)
- B – ISO 3019/2 100A2HW

**6 Shaft end**

- 01 – SAE J744 25–1  
(1.00 inch keyed shaft)
- 02 – SAE J744 25–4  
(B–B splined shaft)
- 03 – ISO 3019/2 E25N  
(25mm keyed shaft)
- 05 – SAE J744 32–1  
(1.25 inch keyed shaft)
- 06 – SAE J744 32–4  
(C splined shaft)
- 07 – ISO 3019/2 E32N  
(32mm keyed shaft)

**7 Shaft seal**

- A – Single, primary
- B – Double, secondary (spring side out)
- C – Double, secondary (spring side in)

**8 Seal type**

- N – Standard, buna N
- V – Viton
- W – Buna N with Viton shaft seals

**9 Outlet port no. 1 position (viewed from cover end)**

- A – Outlet port no.1 opposite inlet port
- B – Outlet port no.1 90° counterclockwise from inlet port
- C – Outlet port no. 1 inline with inlet port
- D – Outlet port no.1 90° clockwise from inlet port

**10 Outlet port no. 2 position (viewed from cover end)**

- A – Outlet port no.2 opposite inlet port
- B – Outlet port no.2 90° counterclockwise from inlet port
- C – Outlet port no.2 inline with inlet port
- D – Outlet port no.2 90° clockwise from inlet port

**11 Design level**

Subject to change. Dimensions remain the same for designs 10 through 19.

**12 Rotation (viewed from shaft end)**

- R – Right hand (clockwise)
- L – Left hand (counterclockwise)

# 2525VMQ Installation Dimensions

Millimeters (inches)

For shaft dimensions, see page A.78.

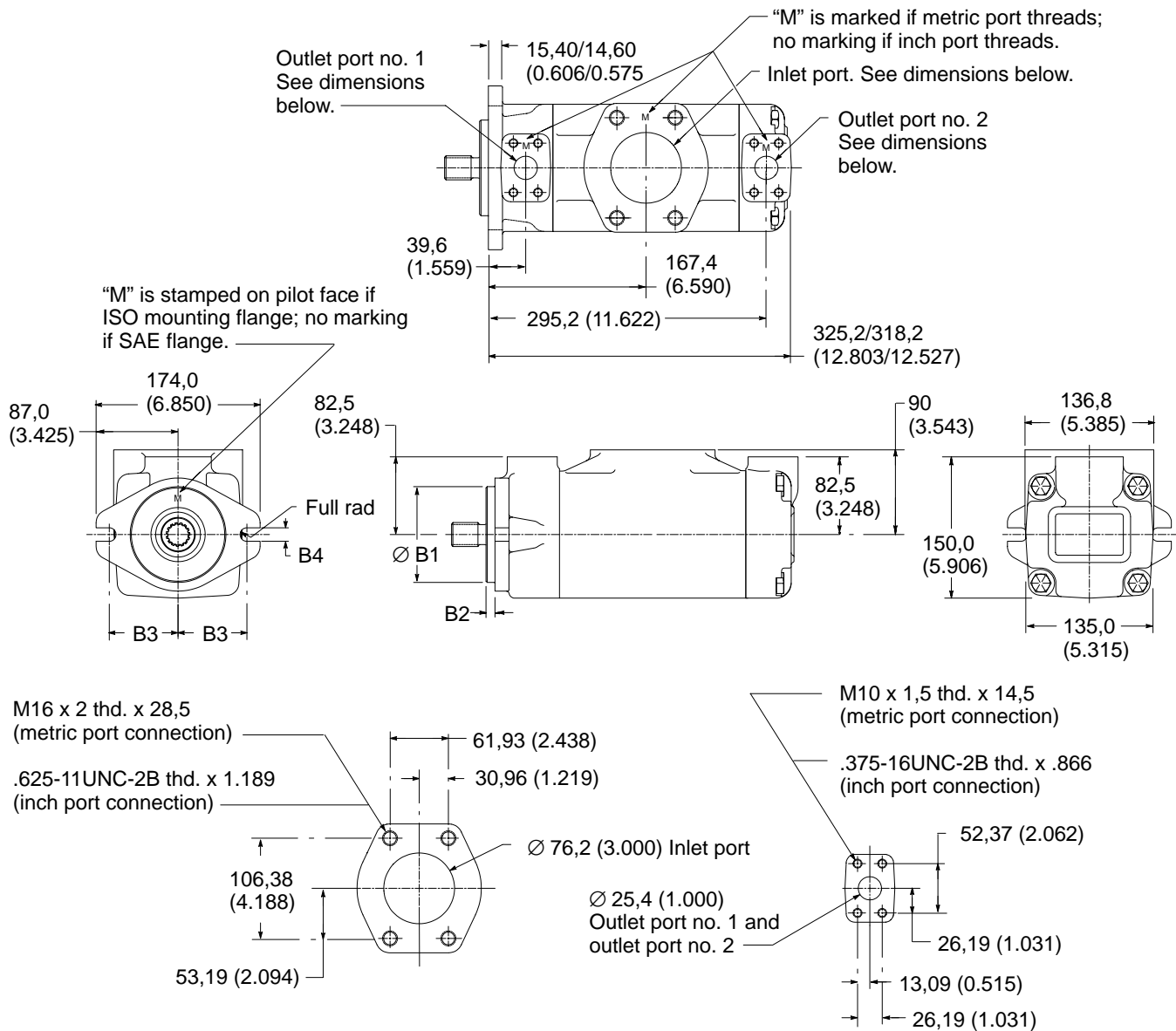

Flange				
Type	Ø B1	B2	B3	B4
SAE 101-2	101,60/101,55 (4.000/3.998)	9,70/9,19 (0.382/0.362)	73,00 (2.874)	14,55/14,17 (0.572/0.557)
ISO 3019/2 100A2HW	100,00/99,946 (3.937/3.935)	9,50/9,00 (0.374/0.354)	70,00 (2.756)	14,27/14,00 (0.562/0.551)

# 3525VMQ Typical Performance Data

## Maximum Operating Pressure

230 bar (3300 psi) for front section of 3525VMQ. 260 bar (3800 psi) for rear section of 3525VMQ.

230 bar (3300 psi) for either section of 3535VMQ.

## Maximum Transient Pressure (peak <0.5 sec)

250 bar (3600 psi) for front section of 3525VMQ. 290 bar (4200 psi) for rear section of 3525VMQ.

250 bar (3600 psi) for either section of 3535VMQ.

## Industrial Displacement, Speed, Flow, and Power Ratings 120° F, SAE10W oil, 0 psig inlet

Ring Size Code	Maximum Geometric Displacement cm <sup>3</sup> /r (in <sup>3</sup> /r)	Maximum Operating Speed rpm	Output Flow at 1500 rpm, 210 bar (3000 psi) l/min (USgpm)	Input Power at 1500 rpm, 210 bar (3000 psi) kw (hp)	Output Flow at 1800 rpm, 210 bar (3000 psi) l/min (USgpm)	Input Power at 1800 rpm, 210 bar (3000 psi) kw (hp)
090	90 (5.49)	1800	121,8 (32.2)	50,1 (67.1)	149 (39.4)	60,0 (80.4)
100	100 (6.10)	1800	136,8 (36.2)	55,7 (74.7)	167 (44.1)	66,6 (89.4)
112	112 (6.83)	1800	154,6 (40.9)	62,3 (83.5)	189 (49.8)	74,6 (100.0)
125	125 (7.63)	1800	174,4 (46.1)	69,6 (93.3)	212 (56.0)	83,3 (112.0)
135	135 (8.24)	1800	189,4 (50.1)	75,2 (100.8)	230 (60.8)	90,0 (120.7)
010	10 (0.62)	1800	11,39 (3.01)	6,24 (8.37)	14,7 (3.88)	7,55 (10.12)
016	16 (0.98)	1800	20,24 (5.35)	9,29 (12.46)	25,32 (6.69)	11,21 (15.03)
020	20 (1.23)	1800	26,38 (6.97)	11,41 (15.30)	32,70 (8.64)	13,75 (18.44)
025	25 (1.58)	1800	34,98 (9.24)	14,37 (19.28)	43,02 (11.37)	17,31 (23.21)
032	32 (1.96)	1800	44,32 (11.71)	17,59 (23.59)	54,23 (14.33)	21,17 (28.39)
040	40 (2.44)	1800	50,14 (13.25)	22,88 (30.68)	61,74 (16.31)	27,46 (36.82)
045	45 (2.75)	1800	57,63 (15.23)	25,46 (34.14)	70,74 (18.69)	30,56 (40.98)
050	50 (3.05)	1800	65,13 (17.21)	28,04 (37.61)	79,73 (21.07)	33,66 (45.14)
063	63 (3.84)	1800	84,55 (22.34)	34,74 (46.58)	103,03 (27.22)	41,69 (55.91)
071	71 (4.33)	1800	96,59 (25.52)	38,89 (52.15)	117,48 (31.04)	46,67 (62.59)
080	80 (4.88)	1800	110,11 (29.09)	43,55 (58.40)	133,71 (35.33)	52,26 (70.09)

### Notes:

Do not operate at speeds, pressures, and/or viscosities where internal leakage exceeds 50% of theoretical value.; i.e., actual flow must exceed 50% of theoretical flow.

Maximum speed rating for double pumps is limited to lowest speed rating of cartridges contained therein.

# 3525VMQ Typical Performance Data

## Mobile Displacement, Speed, Flow, and Power Ratings 180° F, SAE 10W oil, 0 psig inlet

Ring Size Code	Maximum Geometric Displacement cm <sup>3</sup> /r (in <sup>3</sup> /r)	Maximum Operating Speed rpm	Output Flow at Maximum rpm, 210 bar (3000 psi) l/min (USgpm)	Input Power at Maximum rpm, 210 bar (3000 psi) kw (hp)
090	90 (5.49)	2400	188,6 (49.9)	79,9 (107.1)
100	100 (6.10)	2400	212,4 (56.2)	89,0 (119.4)
112	112 (6.83)	2400	241,2 (63.8)	99,5 (133.4)
125	125 (7.63)	2400	272,6 (72.0)	111,0 (148.9)
135	135 (8.24)	2200	270 (71.4)	110,2 (147.7)
010	10 (0.62)	3000	22,38 (5.91)	12,92 (17.33)
016	16 (0.98)	3000	40,07 (10.59)	19,03 (25.51)
020	20 (1.23)	3000	52,36 (13.83)	23,26 (31.19)
025	25 (1.58)	3000	69,57 (18.38)	29,19 (39.15)
032	32 (1.96)	3000	88,25 (23.32)	35,63 (47.78)
040	40 (2.44)	2600	81,19 (21.45)	39,96 (53.59)
045	45 (2.75)	2600	94,18 (24.88)	44,44 (59.59)
050	50 (3.05)	2600	107,17 (28.32)	48,92 (65.60)
063	63 (3.84)	2600	140,83 (37.21)	60,52 (81.16)
071	71 (4.33)	2600	161,70 (42.72)	67,72 (90.81)
080	80 (4.88)	2400	169,43 (44.76)	69,80 (93.60)

**Notes:**

Do not operate at speeds, pressures, and/or viscosities where internal leakage exceeds 50% of theoretical value.; i.e., actual flow must exceed 50% of theoretical flow.

Maximum speed rating for double pumps is limited to lowest speed rating of cartridges contained therein.

# 3525VMQ Typical Sound Data

120° F, SAE 10W oil, 0 psig inlet,  
both cartridges loaded

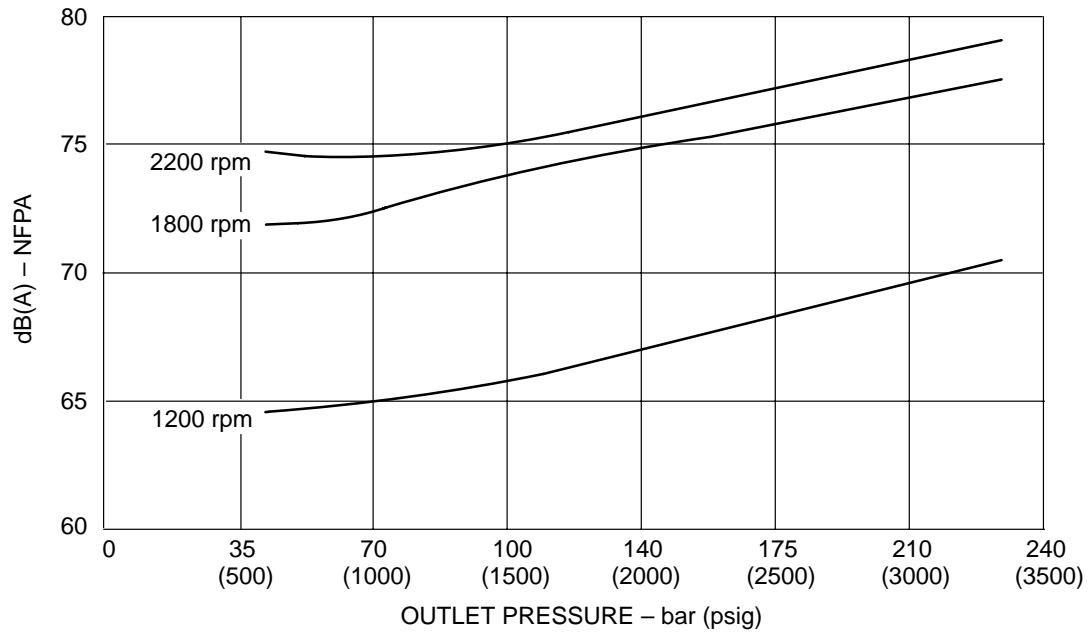

## Delivery and Input Power

3525VMQ and 3535VMQ delivery and input power can be determined from 35VMQ curves beginning on page A.56 and 25VMQ curves beginning on page A.33.

# 3525VMQ Model Code

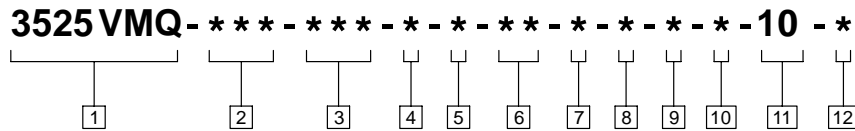

**1 Series designation (frame size)**

3525VMQ – 100 to 215 cm<sup>3</sup>/r  
(6.11 to 13.12 in<sup>3</sup>/r)

**2 Displacement – front section**

35\*\*VMQ

- 090 – 90 cm<sup>3</sup>/r (5.49 in<sup>3</sup>/r)
- 100 – 100 cm<sup>3</sup>/r (6.10 in<sup>3</sup>/r)
- 112 – 112 cm<sup>3</sup>/r (6.83 in<sup>3</sup>/r)
- 125 – 125 cm<sup>3</sup>/r (7.63 in<sup>3</sup>/r)
- 135 – 135 cm<sup>3</sup>/r (8.24 in<sup>3</sup>/r)

**3 Displacement – rear section**

\*\*25VMQ

- 010 – 10 cm<sup>3</sup>/r (0.62 in<sup>3</sup>/r)
- 016 – 16 cm<sup>3</sup>/r (0.98 in<sup>3</sup>/r)
- 020 – 20 cm<sup>3</sup>/r (1.23 in<sup>3</sup>/r)
- 025 – 25 cm<sup>3</sup>/r (1.58 in<sup>3</sup>/r)
- 032 – 32 cm<sup>3</sup>/r (1.96 in<sup>3</sup>/r)
- 040 – 40 cm<sup>3</sup>/r (2.44 in<sup>3</sup>/r)
- 045 – 45 cm<sup>3</sup>/r (2.75 in<sup>3</sup>/r)
- 050 – 50 cm<sup>3</sup>/r (3.05 in<sup>3</sup>/r)
- 063 – 63 cm<sup>3</sup>/r (3.84 in<sup>3</sup>/r)
- 071 – 71 cm<sup>3</sup>/r (4.33 in<sup>3</sup>/r)
- 080 – 80 cm<sup>3</sup>/r (4.88 in<sup>3</sup>/r)

**4 Port connection**

- A – SAE 4-bolt flange (SAE J518)
- B – Metric 4-bolt flange (ISO 6162)

**5 Flange mounting style**

- A – SAE J744 127–2 (SAE C)
- B – ISO 3019/2 125A2HW

**6 Shaft end**

- 01 – SAE J744 32–1  
(1.25 in keyed shaft)
- 02 – SAE J744 32–4  
(C splined shaft)
- 03 – ISO 3019/2 E32N  
(32mm keyed shaft)
- 05 – SAE J744 38–1  
(1.50 in keyed shaft)
- 06 – SAE J744 38–4  
(C–C splined shaft)
- 07 – ISO 3019/2 E40N  
(40mm keyed shaft)

**7 Shaft seal**

- A – Single, primary
- B – Double, secondary (spring side out)
- C – Double, secondary (spring side in)

**8 Seal type**

- N – Standard, buna N
- V – Viton
- W – Buna N with Viton shaft seals

**9 Outlet port no. 1 position (viewed from cover end)**

- A – Outlet port no.1 opposite inlet port
- B – Outlet port no.1 90° counterclockwise from inlet port
- C – Outlet port no.1 in line with inlet port
- D – Outlet port no.1 90° clockwise from inlet port

**10 Outlet port no. 2 position (viewed from cover end)**

- A – Outlet port no.2 135° counterclockwise from inlet port
- B – Outlet port no.2 45° counterclockwise from inlet port
- C – Outlet port no.2 45° clockwise from inlet port
- D – Outlet port no.2 135° clockwise from inlet port

**11 Design level**

Subject to change. Dimensions remain the same for designs 10 through 19.

**12 Rotation (viewed from shaft end)**

- R – Right hand (clockwise)
- L – Left hand (counterclockwise)

# 3525VMQ Installation Dimensions

Millimeters (inches)

For shaft dimensions, see page A.79.

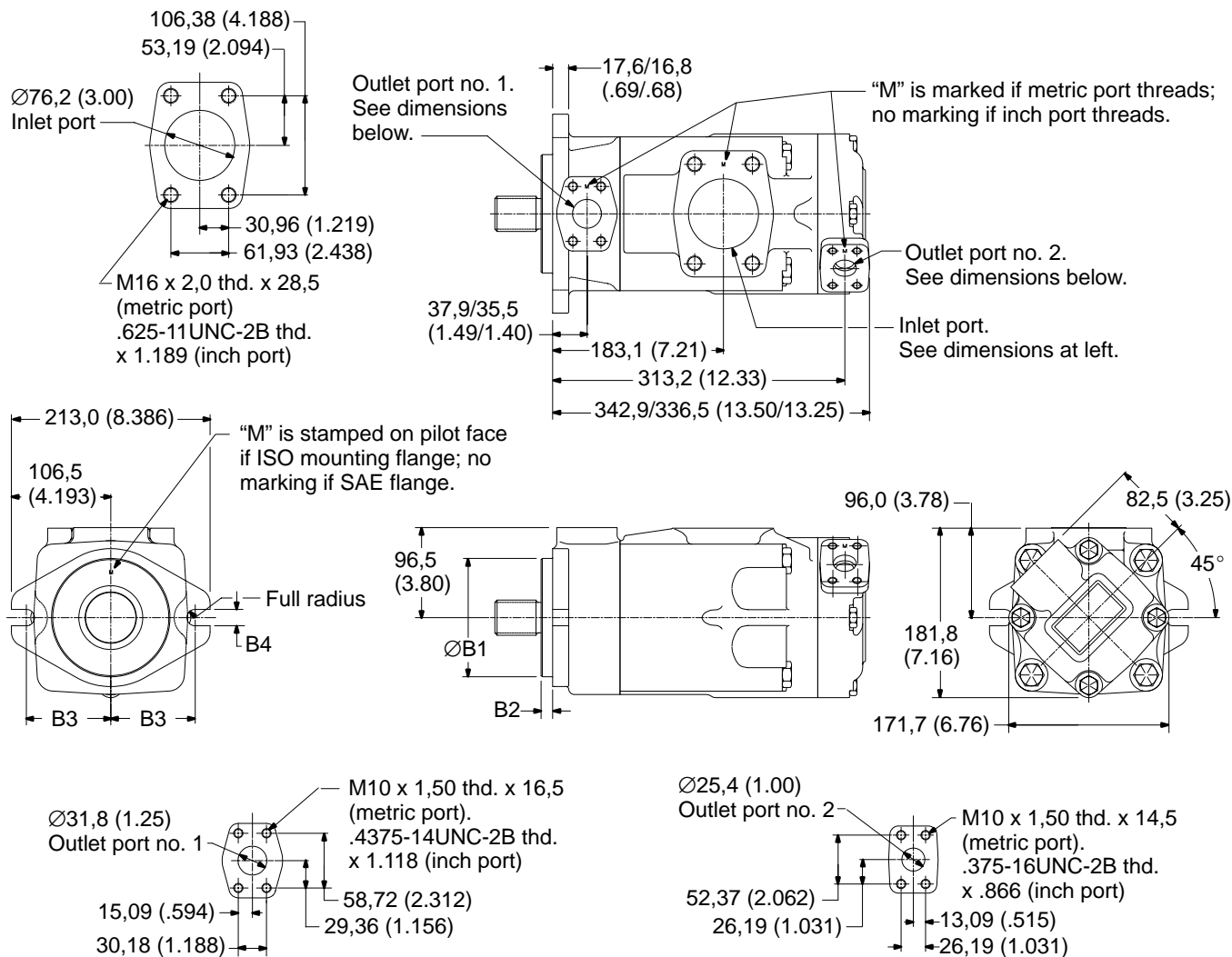

Flange Type	Ø B1	B2	B3	B4
SAE 127-2	127,00/126,95 (5.000/4.998)	12,70/12,19 (0.500/0.480)	90,50 (3.563)	17,75/17,37 (0.698/0.683)
ISO 3019/2 125A2HW	125,000/124,937 (4.921/4.919)	9,50/9,00 (0.374/0.354)	90,00 (3.543)	18,27/18,00 (0.719/0.709)

# Shaft Dimensions

## 25VMQ and 2525VMQ

millimeters (inches)

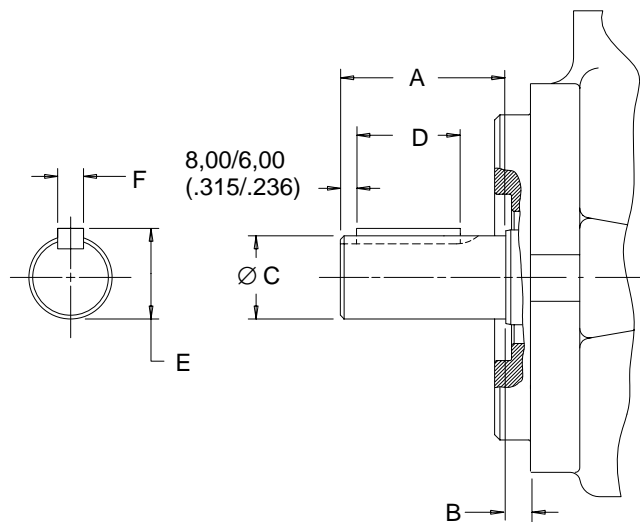

### Keyed Shafts

01, 03, 05, 07

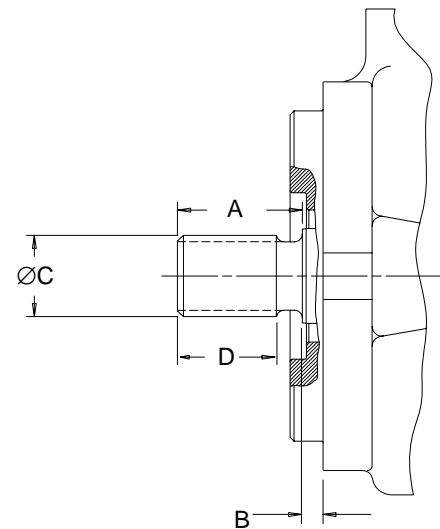

### Splined Shafts

02, 06, 09

Keyed Shaft	Shaft Designation	Dimensions					
		A	B	$\varnothing C$	D	E	F
01	SAE J744 25-1	70,00 (2.756)	8,80/7,20 (0.346/0.283)	25,40/25,35 (1.000/0.998)	49,23 (1.938)	28,23/27,97 (1.111/1.101)	6,375/6,350 (0.251/0.250)
03	ISO 3019/2 E25N	42,00 (1.654)	11,00/9,40 (0.433/0.370)	25,013/24,992 (0.985/0.984)	18,00 (0.709)	27,992/27,723 (1.102/1.091)	8,000/7,964 (0.315/0.314)
05	SAE J744 32-1	76,00 (2.992)	8,80/7,20 (0.346/0.283)	31,75/31,70 (1.250/1.248)	50,80 (2.000)	35,33/35,07 (1.390/1.381)	7,963/7,938 (0.314/0.313)
07	ISO 3019/2 E32N	58,00 (2.283)	11,00/9,40 (0.433/0.370)	32,027/32,002 (1.261/1.260)	34,00 (1.338)	35,002/34,738 (1.378/1.368)	10,000/9,964 (0.394/0.392)

Splined Shaft	Shaft Designation	Dimensions				External Involute Spline Data (All splines are tolerance class 7, ANSI B92.1a-1976, flat root, side fit)		
		A	B	$\varnothing C$ max.	D	Teeth	Pitch	PR Angle
02	SAE J744 25-4	38,00 (1.496)	8,80/7,20 (0.346/0.283)	24,99 (0.984)	28,00 (1.102)	15	16/32	30°
06	SAE J744 32-4	48,00 (1.890)	8,80/7,20 (0.346/0.283)	31,22 (1.229)	38,00 (1.496)	14	12/24	30°
09	SAE J744 22-4	33,00 (1.299)	8,80/7,20 (0.346/0.283)	21,82 (0.859)	24,90 (0.980)	13	16/32	30°

## 35VMQ and 3525VMQ

millimeters (inches)

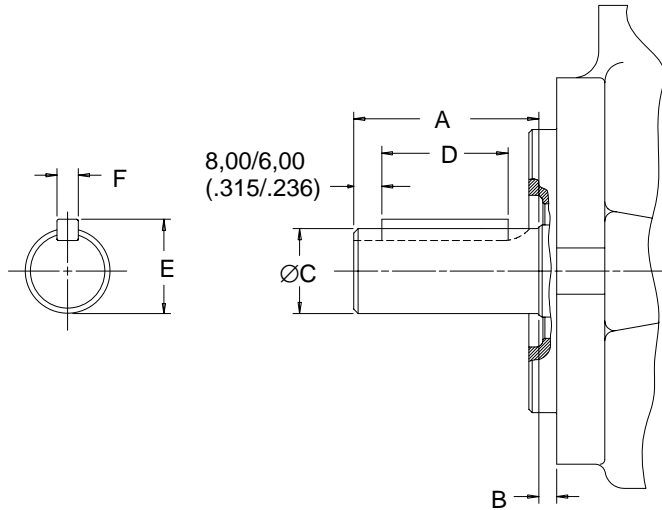

### Keyed Shafts

01, 03, 05, 07

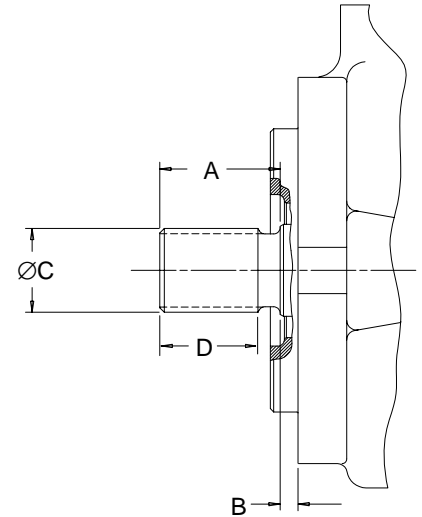

### Splined Shafts

02, 06

Keyed Shaft	Shaft Designation	Dimensions					
		A	B	ØC	D	E	F
01	SAE J744 32-1	76,00 (2.992)	8,80/7,20 (0.346/0.283)	31,75/31,70 (1.250/1.248)	49,23 (1.938)	35,33/35,07 (1.391/1.381)	7,963/7,938 (0.314/0.313)
03	ISO 3019/2 E32N	58,00 (2.283)	11,00/9,40 (0.433/0.370)	32,027/32,002 (1.261/1.260)	34,00 (1.338)	35,002/34,738 (1.378/1.368)	10,000/9,964 (0.394/0.392)
05	SAE J744 38-1	83,00 (3.268)	8,80/7,20 (0.346/0.283)	38,10/38,05 (1.500/1.498)	57,15 (2.250)	42,40/42,14 (1.669/1.659)	9,550/9,525 (0.376/0.375)
07	ISO 3019/2 E40N	82,00 (3.228)	11,00/9,40 (0.433/0.370)	40,027/40,002 (1.576/1.575)	56,00 (2.205)	43,002/43,737 (1.693/1.722)	12,000/11,957 (0.472/0.471)

Splined Shaft	Shaft Designation	Dimensions				External Involute Spline Data (All splines are tolerance class 7, ANSI B92.1a-1976, flat root, side fit)		
		A	B	ØC max.	D	Teeth	Pitch	PR Angle
02	SAE J744 32-4	48,00 (1.890)	8,80/7,20 (0.346/0.283)	31,22 (1.229)	38,00 (1.496)	14	12/24	30°
06	SAE J744 38-4	54,00 (2.126)	8,80/7,20 (0.346/0.283)	37,57 (1.479)	44,00 (1.732)	17	12/24	30°

# Torque Loading for Direct Drives

For correct pump shaft selection, peak transient system pressure must be used to determine drive torque. The torque, taken from the graph below, must not exceed the torque limit in the shaft torque table.

## Double pumps

When both cartridges are to be on-load together, the sum of their separate torques must not exceed the torque limit in the table.

## Example:

A 3525VMQ-135-063 pump peaking at 250 bar (3600 psi) front section and 290 bar (4200 psi) rear section will require approximately 900 Nm (7965 lb-in) input torque. Therefore, all listed shafts are acceptable except numbers 01 and 03.

## Shaft Torque

Pump Series	Shaft No.	Maximum Input Torque Nm (lb-in)	
25VMQ, 2525VMQ	01	407 (3600)	
	02	621 (5500)	
	03	407 (3600)	
	05	814 (7200)	
	06	814 (7200)	
	07	814 (7200)	
	09	328 (2900)	
	35VMQ, 3525VMQ	01	814 (7200)
		02	1017 (9000)
03		814 (7200)	
05		1130 (10,000)	
06		1130 (10,000)	
07		1130 (10,000)	

## NOTE

To realize the high input torque levels for keyed shafts (nos. 1, 3, 5 and 7), the corners of the key must be chamfered 0,76 to 1,02 mm x 45° to clear the radii in the keyway. (Vickers ships keyed shafts with the corners of the key already chamfered.) Also, the key must be installed in the keyway 8,00/6,00 mm back from the end of the shaft as shown on pages A.78 and A.79.

Spline shaft ends (nos. 2, 6 and 9) must be lubricated by gearbox lubricant or anti-seizure grease to prevent spline wear and fretting.

## Input Torque Requirement

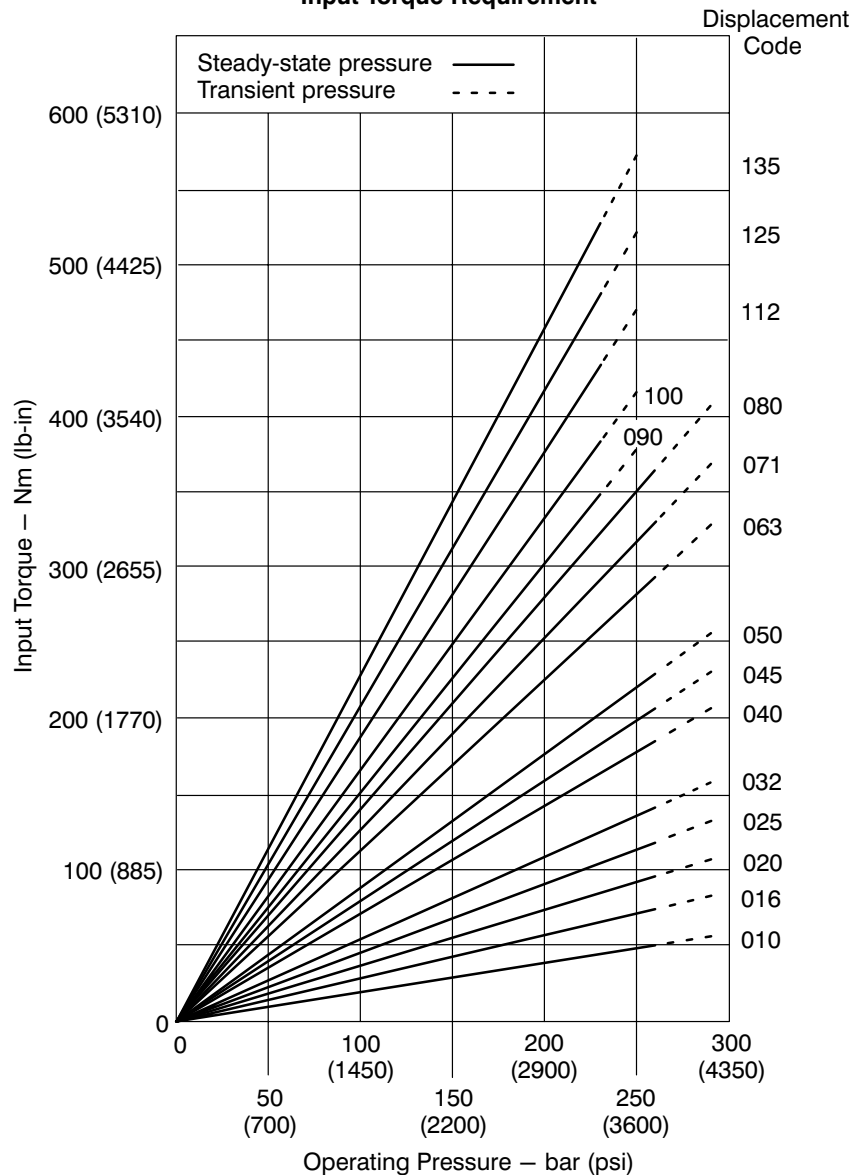

# Fluid Cleanliness

Proper fluid condition is essential for long and satisfactory life of hydraulic components and systems. Hydraulic fluid must have the correct balance of cleanliness, materials, and additives for protection against wear of components, elevated viscosity and inclusion of air.

Essential information on the correct methods for treating hydraulic fluid is included in Vickers publication 561 "Vickers Guide to Systemic Contamination Control," available from your local Vickers distributor or by contacting Vickers, Incorporated.

Recommendations on filtration and the selection of products to control fluid condition are included in 561.

Recommended cleanliness levels, using petroleum oil under common conditions, are based on the highest fluid pressure levels in the system and are coded in the chart below. Fluids other than petroleum, severe service cycles, or temperature extremes are cause for adjustment of these cleanliness codes. See Vickers publication 561 for exact details.

Vickers products, as any components, will operate with apparent satisfaction in fluids with higher cleanliness codes than those described. Other manufacturers will often recommend levels above those specified. Experience has shown, however, that life of any hydraulic component is shortened in fluids with higher cleanliness codes than those listed below. These codes have been proven to provide a long, trouble-free service life for the products shown, regardless of the manufacturer.

Product	System Pressure Level psi		
	<2000	2000–3000	3000+
<b>Vane pumps, fixed</b>	<b>20/18/15</b>	<b>19/17/14</b>	<b>18/16/13</b>
Vane pumps, variable	18/16/14	17/15/13	
Piston pumps, fixed	19/17/15	18/16/14	17/15/13
Piston pumps, variable	18/16/14	17/15/13	16/14/12
Directional valves	20/18/15	20/18/15	19/17/14
Proportional valves	17/15/12	17/15/12	15/13/11
Servo valves	16/14/11	16/14/11	15/13/10
Pressure/Flow controls	19/17/14	19/17/14	19/17/14
Cylinders	20/18/15	20/18/15	20/18/15
Vane motors	20/18/15	19/17/14	18/16/13
Axial piston motors	19/17/14	18/16/13	17/15/12
Radial piston motors	20/18/14	19/17/13	18/16/13

# Additional Data

## Fluid Selection

Fluid in a hydraulic system performs the multiple functions of transmission of power, lubrication of components, and cooling. It is a vital factor in a hydraulic system and proper selection is a necessity for satisfactory operation and life of components.

Basic requirements of a good petroleum oil for hydraulic systems are:

- 1) sufficient anti-wear additives,
- 2) proper viscosity at the operating temperature, and
- 3) adequate rust and oxidation inhibitors.

A good quality fluid from reputable sources will provide these characteristics.

Two specific types of oil meet the requirements of modern hydraulic systems:

- Anti-wear type hydraulic oils that comply with the pump wear tests of ASTM-D-2882
- Automotive crankcase oils having the letter designations "SC", "SD", "SE", "SF", or "SG" per SAE J183 JUN89.

For additional information on the correct viscosity and proper selection of fluids for hydraulic systems, refer to Vickers publication 694.

## Moments of Inertia

<b>Model Series</b>	<b>Moment of Inertia</b> Nm/sec <sup>2</sup> (lb. in./sec <sup>2</sup> )
25VMQ (10 – 32 cm <sup>3</sup> /r)	0,00075 (0.0066)
25VMQ (40 – 80 cm <sup>3</sup> /r)	0,00103 (0.0091)
35VMQ	0,0025 (0.022)
2525VMQ	0,0019 (0.017)
3525VMQ	0,0043 (0.038)

## Weights

<b>Model Series</b>	<b>Approximate Dry Weight</b> kg (lbs.)
25VMQ	20,8 (45.8)
35VMQ	33,9 (74.5)
2525VMQ	36,8 (81)
3525VMQ	50,5 (111)